



POINT-OF-USE ELECTRIC TANKLESS COMMERCIAL/RESIDENTIAL

EASY INSTALLATION

- Compact size perfect for point-of-use applications close to fixtures
- Mounts easily to the wall
- No venting required
- ½" NPT water connection
- No T&P valve required (check local codes)

WIDE ARRAY OF MODELS AND MODES OF OPERATION

- 1.75kW – 3.5kW, 120V
- 3.5kW – 11kW, 240V (208V)
- Single Phase, 50/60 Hz
- Two mode options, easy switching
- Lavatory mode, default 105°F; temp range 80°F – 149°F
- Emergency eye wash mode, 85°F

ONBOARD SELF-DIAGNOSTICS & TROUBLESHOOTING

- Onboard self-diagnostics to monitor performance and protect the unit
- Bright LED display for status updates and making system selections and adjustments
- Error codes for troubleshooting and faster resolution

HIGHLY EFFICIENT & RELIABLE THERMOSTATIC DESIGN

- On-demand water heater capable of supplying endless hot water when appropriately sized
- Ultra-low activation of 0.17 GPM min.
- Energy efficiency 0.91 UEF or higher
- Dry-fire protection to prevent premature element failures
- Secondary temperature regulation to limit hot water output appropriate for use with hand or eye washing applications
- Scale detection (Patent Pending) and easy maintenance for extended service life of the heater

CONSTRUCTION

- Housing – Bayblend® FR3010 plastic, dark gray
- Chamber Material – Entec Nylon, glass-filled
- Sheathed copper elements for longer life

WARRANTY

- 6-Year limited warranty on chambers
- 1-Year limited warranty on all parts
- For complete information, consult the written warranty





POINT-OF-USE ELECTRIC TANKLESS COMMERCIAL/RESIDENTIAL

PRODUCT SPECIFICATIONS								
Model Number	Voltage (V)	Number of Elements	Total Input Wattage (kW)	Wattage per Element	Total Current Draw (Amps)	Recommended Canada Circuit Breaker Size (Amps)	Conductor Size (AWG)	Activation GPM
SSETU-18K	120	2	1.75	0.88	14.58	20	14	0.17
SSETU-24K	120	2	2.40	1.20	20.00	25	12	0.17
SSETU-30K	120	2	3.00	1.50	25.00	35	10	0.17
SSETU-35K	120	2	3.50	1.75	29.17	40	10	0.17
SSETU-35E	240+	2	3.50	1.75	14.58	20	14	0.17
SSETU-45E	240+	2	4.50	2.25	18.75	25	12	0.17
SSETU-55E	240+	2	5.50	2.75	22.92	30	10	0.17
SSETU-70E	240+	4	7.00	1.75	29.17	40	10	0.17
SSETU-90E	240+	4	9.00	2.25	37.50	50	8	0.17
SSETU-110E	240+	4	11.00	2.75	45.83	60	8	0.17

Copper conductors only. All wiring/conductors must be rated for 90°C or greater.

+ This model may be connected to a 208 VAC supply with reduced power output. Connection to 208 VAC may require different breaker and/or wire size than shown in the table.

NOTICE: Incoming line voltage variations may result in nuisance breaker trips. Contact Technical Support if there are multiple breaker trips when the recommended breaker size is in use.

Volts	kW	GPM AT TEMPERATURE RISE												
		25°F	30°F	35°F	40°F	45°F	50°F	55°F	60°F	65°F	70°F	75°F	80°F	85°F
120V	1.75kW	0.47	0.39	0.33	0.29	0.26	0.23	0.21	0.20	0.18	0.17	-	-	-
	2.4kW	0.64	0.54	0.46	0.40	0.36	0.32	0.29	0.27	0.25	0.23	0.21	0.20	0.19
	3kW	0.80	0.67	0.57	0.50	0.45	0.40	0.36	0.33	0.31	0.29	0.27	0.25	0.24
	3.5kW	0.94	0.78	0.67	0.59	0.52	0.47	0.43	0.39	0.36	0.33	0.31	0.29	0.28
240V (208V)	3.5kW	0.94	0.78	0.67	0.59	0.52	0.47	0.43	0.39	0.36	0.33	0.31	0.29	0.28
	4.5kW	1.20	1.00	0.86	0.75	0.67	0.60	0.55	0.50	0.46	0.43	0.40	0.38	0.35
	5.5kW	1.47	1.23	1.05	0.92	0.82	0.74	0.67	0.61	0.57	0.53	0.49	0.46	0.43
	7kW	1.87	1.56	1.34	1.17	1.04	0.94	0.85	0.78	0.72	0.67	0.62	0.59	0.55
	9kW	2.41	2.01	1.72	1.50	1.34	1.20	1.09	1.00	0.93	0.86	0.80	0.75	0.71
	11kW	2.94	2.45	2.10	1.84	1.63	1.47	1.34	1.23	1.13	1.05	0.98	0.92	0.87

Cold water inlet temperatures raised to 105°F setpoint.



POINT-OF-USE ELECTRIC TANKLESS COMMERCIAL/RESIDENTIAL

DIMENSIONS

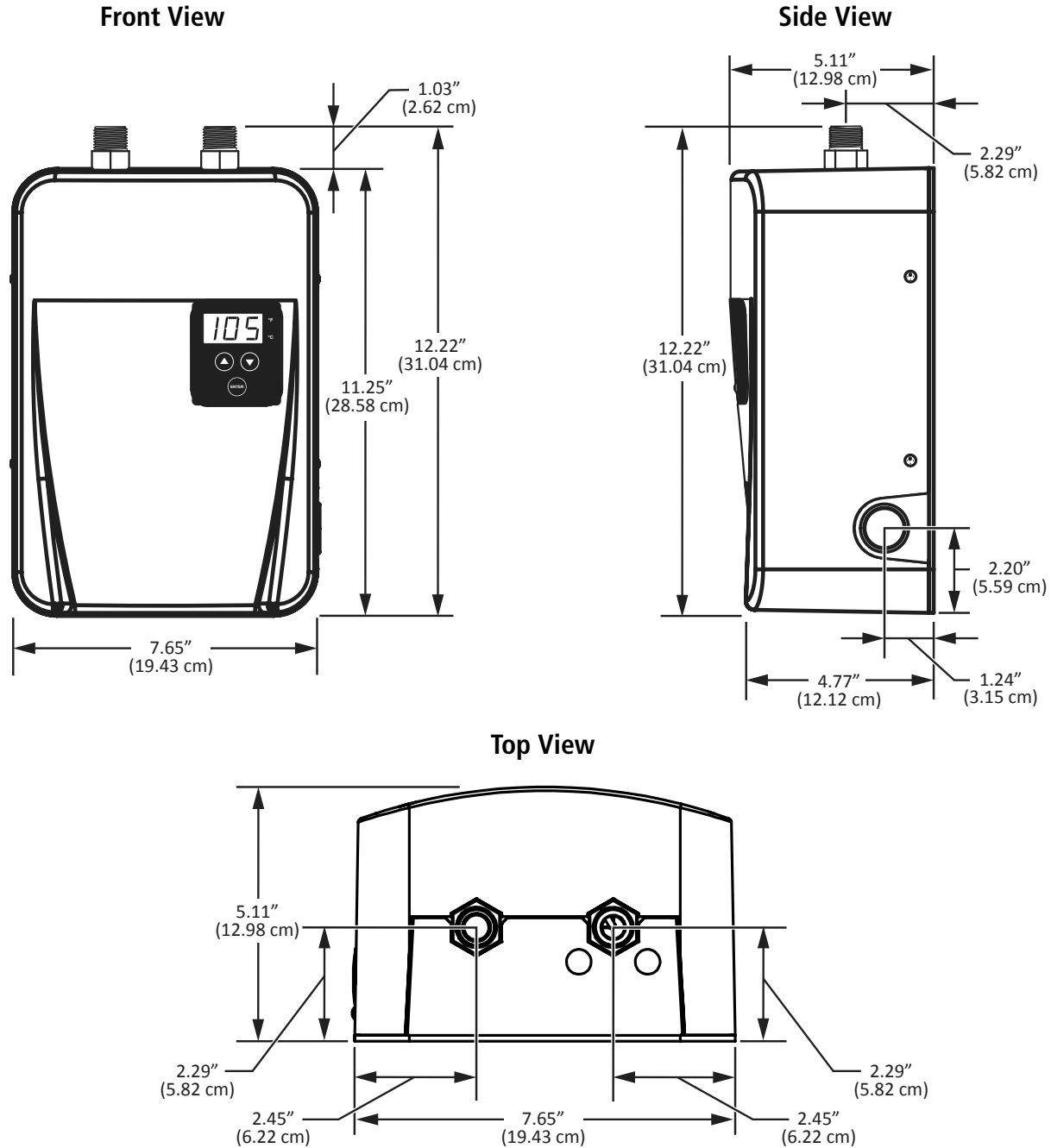

DIMENSIONS – SHIPPING

Models	Width in (cm)	Height in (cm)	Depth in (cm)	Weight lb (kg)
1.75kW - 5.5kW	11.25 (28)	15.5 (38)	8 (20)	6.0 (2.7)
7.0kW - 11kW	11.25 (28)	15.5 (38)	8 (20)	8.0 (3.6)



POINT-OF-USE ELECTRIC TANKLESS COMMERCIAL/RESIDENTIAL

INSTALLATION

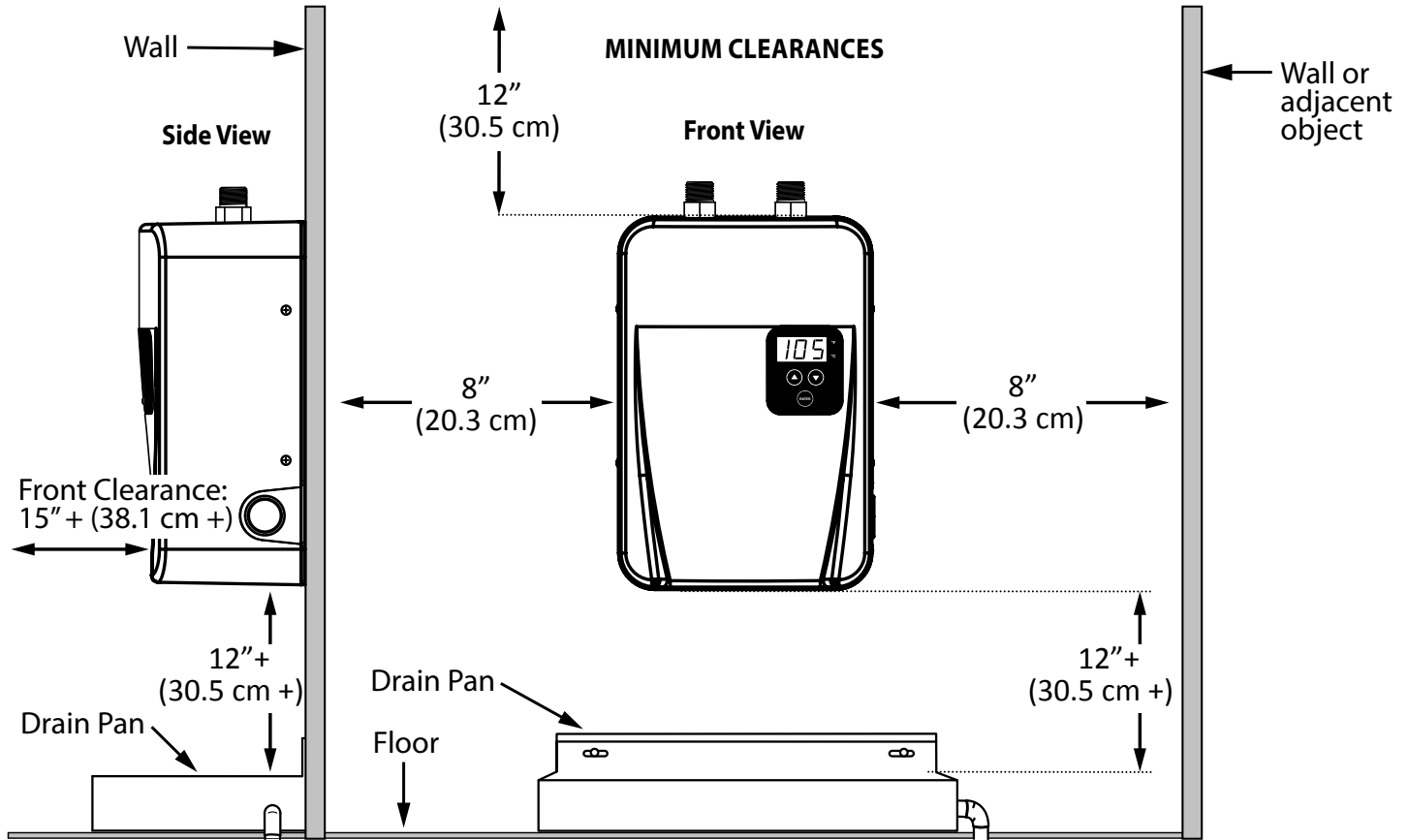

ORIENTATION & CLEARANCE

- All models must be oriented with the inlet and outlet facing upward.
- Top clearance – a minimum of 12 inches (30.5 cm) to provide access for plumbing connections.
- Side clearance – a minimum of 8 inches (20.3 cm) to remove the screws and protective cover and to provide access for electrical wires to enter through the side of the unit.
- Bottom clearance – a minimum of 12 inches (30.5 cm) for access to and maintenance of heating elements. Do not store any items beneath the water heater.
- Front clearance – a minimum of 8 inches (20.3 cm). In the absence of a door or removable access panel in front of the heater, allow a minimum of 15 inches (38.1 cm) for cover removal and ease of service.

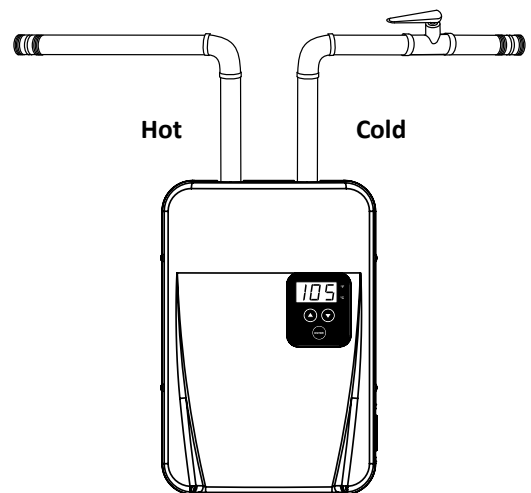

For Technical Information call 1-888-599-2837. A. O. Smith Enterprises Ltd. reserves the right to make product changes or improvements without prior notice.