

## PROLINE® MASTER SMART ELECTRIC WATER HEATERS

Get smarter hot water from A. O. Smith. Our ProLine® Master Smart Electric water heaters are designed with iCOMM™ Wi-Fi technology and leak detection to provide homeowners with greater control and added peace of mind.

### ELECTRONIC CONTROLS WITH WIFI CONNECTIVITY

- Standard and vacation operating modes
- Seven-segment display
- Diagnostic feedback
- Element "Dry-Fire" protection

### REMOTE CONTROL THROUGH THE A. O. SMITH APP

- Change water temperature and operating mode remotely
- View energy usage and hot water availability
- Schedule hot water demand for optimized performance

### LEAK DETECTION SENSOR

- Sounds an audible alarm when water is detected

### ENHANCED HEATING ELEMENTS

- Dual elements for the fastest recovery and reliable operation
- Stainless steel elements last longer than standard copper elements

### SELF CLEANING DIP TUBE

- Helps reduce lime and sediment buildup and maximizes hot water output.
- Made from long-lasting PEX cross-linked polymer

### COREGARD™ ANODE ROD

- A stainless steel core extends the life of the anode rod allowing superior tank protection far longer than standard anode rods

### BLUE DIAMOND® GLASS COATING

- Provides superior corrosion resistance compared to industry standard glass lining

### ENHANCED-FLOW BRASS DRAIN VALVE

- Solid brass, tamper resistant, enhanced-flow, ball type, drain valve
- Uses a standard female hose fitting that allows for fast and easy draining during maintenance
- Designed for easy operation, this valve includes an integral screwdriver slot that features a ¼ turn (open/close) radius, which not only permits full straight-through water flow but also a quick and positive shut off

### CODE COMPLIANCE

- Meets NRCAN standby loss requirements

### CSA CERTIFIED AND ASME RATED T&P RELIEF VALVE

### DESIGN-LISTED BY UNDERWRITERS LABORATORIES

- Certified at 300 psi test pressure and 150 psi working pressure
- Listed according to UL 174 standards governing storage tank-type electric water heaters

### 8-YEAR LIMITED TANK AND PARTS WARRANTY

- For complete information, consult written warranty or go to [hotwatercanada.ca](http://hotwatercanada.ca)

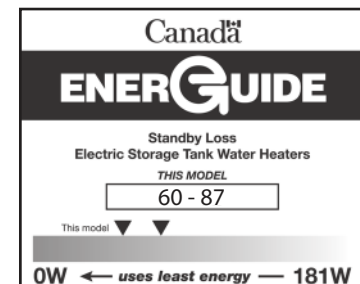



# Commercial-Grade Residential Water Heaters

## SPECIFICATIONS

MODEL	SERIES	CAPACITY			INPUT		STANDBY LOSS WATTS	FIRST HOUR RATING USG (L)	HEIGHT TO TOP OF TANK A IN (CM)	DIAMETER B IN (CM)	SHIPPING WEIGHT LB (KG)	WARRANTY TANK/PARTS YEARS	BC/ON/QC COMPLIANT
		IG	USG	LITRES	240V	208V							
<b>TOP ENTRY</b>													
HEHC-50	100	40	50	182	3,000W	2,253W	60	63 (238)	60 1/4 (153)	20 (51)	106 (48)	8/8	√
HEHC-50	100	40	50	182	3,800W	3,000W	60	74 (280)	59 (150)	20 1/2 (52)	109 (49)	8/8	√
HEHC-80	100	60	80	287	4,500W	3,500W	87	75 (284)	60 1/2 (154)	24 (61)	145 (66)	8/8	√
HEHC-80	100	60	80	287	5,500W	4,000W	87	67 (254)	49 1/4 (125)	23 (58)	117 (53)	8/8	√

3/4" water connections on 8" center.

Equipped as dual element only, no single element configurations available.

Dimensions and specifications subject to change without notice in accordance with our policy of continuous product improvement.

## CONTROL PANEL



## iCOMM™ SMART CONNECTIVITY

Download the free A. O. Smith app to get started.



Apple logo and Apple App Store Logo are trademarks of Apple Inc. Google Play and the Google Play logo are trademarks of Google LLC.

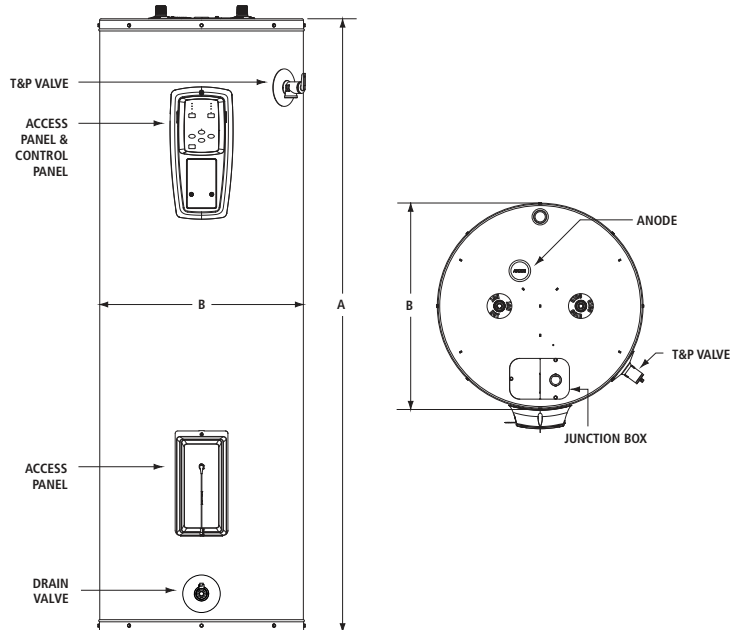
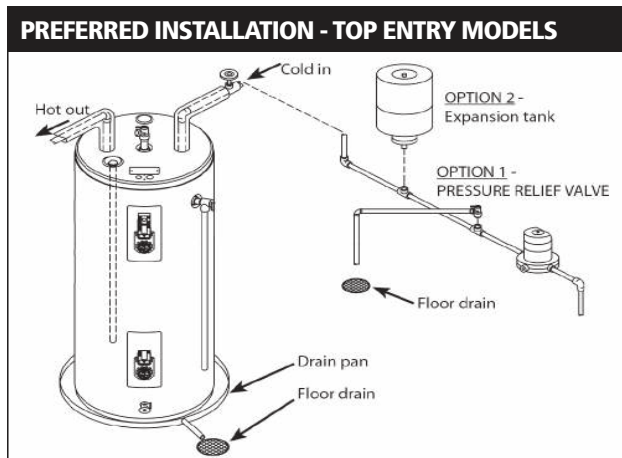

For Technical Information, call 888-599-2837. A. O. Smith Enterprises Ltd. reserves the right to make product changes or improvements without prior notice.