

The Polaris high efficiency gas water heater is the high performance answer for today's hot water needs. It can provide endless hot water* and can be used for a combination of domestic hot water and space heating.

CONDENSING DESIGN

- Operates at up to 96% thermal efficiency which saves money on operating costs compared to a standard 80% efficient gas water heater
- Helical internal heat exchanger keeps hot combustion gases in the tank longer to transfer more heat into the water

STAINLESS STEEL CONSTRUCTION

- Tank and helical heat exchanger are constructed from 444 stainless steel for excellent corrosion resistance without the need for an anode

WHISPER QUIET OPERATION

- Ultra quiet blower and burner to minimize noise

POWER DIRECT VENT DESIGN

- Direct vent using ULC S636, PVC, CPVC or Polypropylene (solid core only) through a sidewall or roof
- Optional concentric vent kit
- 2" pipe vents up to 52 equivalent feet (100-150k BTU/h inputs)
- 3" pipe vents up to 130 equivalent feet

ADVANCED ELECTRONIC CONTROL

- Large touchscreen display
- Precise temperature control
- Advanced water heater status and diagnostics

MODULATING GAS BURNER

- Modulating burner maintains high efficiency operation at lower input rates

SIDE-MOUNTED HOT AND COLD RECIRCULATING TAPS

- Polaris can be easily installed with a recirculation system or as part of a combined domestic & space heating system

FULLY SERVICEABLE FROM THE FRONT

- Two front access panels expose all serviceable components. Modular components are all easily removed

AVAILABLE IN NATURAL GAS OR PROPANE

CSA CERTIFIED AND ASME RATED T&P RELIEF VALVE

10-YEAR LIMITED TANK AND 10-YEAR PARTS WARRANTY

*When sized appropriately. Model PR50-199 can deliver 6.95 GPM continuous flow, based on 65°F inlet water temperature, 120°F outlet temperature.





Polaris™ High-Efficiency Residential Gas Water Heater

PERFORMANCE

Model	Series	Capacity		Maximum Certified Altitude	Input	Recovery Rate at 90°F Temperature Rise	Thermal Efficiency	Warranty Tank/Parts
		USG	L					
NATURAL GAS								
PR 34-100 N	200	34	129	7,700 (2,437)	100,000	129 (488)	96%	10/1
PR 34-130 N	200	34	129	7,700 (2,437)	130,000	168 (636)	96%	10/1
PR 34-150 N	200	34	129	7,700 (2,437)	150,000	190 (719)	94%	10/1
PR 50-130 N	200	50	189	7,700 (2,437)	130,000	165 (625)	95%	10/1
PR 50-150 N	200	50	189	7,700 (2,437)	150,000	190 (719)	95%	10/1
PR 50-175 N	200	50	189	7,700 (2,437)	175,000	222 (840)	96%	10/1
PR 50-199 N	200	50	189	7,700 (2,437)	199,000	253 (958)	96%	10/1

For propane models sub N with P. Natural gas models are series 200. Propane models are series 201. All models comply with national energy efficiency regulations. Input, output and recovery may vary depending upon air inlet and exhaust outlet installations, consult manual for details.

DIMENSIONS & SHIPPING WEIGHT

Model	Height to Top of Tank	Tank Diameter	Height to Heating System Return	Height to Cold Water Inlet	Height to Heating System Outlet	Height to T&P	Height to Gas Supply	Height to Air Inlet	Water Connections	Gas Connections	Vent Diameter	Shipping Weight
	A IN (CM)	B IN (CM)	C IN (CM)	C IN (CM)	D IN (CM)	E IN (CM)	F IN (CM)	G IN (CM)	IN NPT	IN NPT	IN	LB (KG)
NATURAL GAS												
PR 34-100 N	48 ½ (123)	22 (56)	15 ¾ (40)	15 ¾ (40)	40 ½ (103)	41 (104)	6 ¾ (16)	6 ¾ (16)	1	½	2 or 3	150 (68)
PR 34-130 N	48 ½ (123)	22 (56)	15 ¾ (40)	15 ¾ (40)	40 ½ (103)	41 (104)	6 ¾ (16)	6 ¾ (16)	1	½	2 or 3	150 (68)
PR 34-150 N	48 ½ (123)	22 (56)	15 ¾ (40)	15 ¾ (40)	40 ½ (103)	41 (104)	6 ¾ (16)	6 ¾ (16)	1	½	2 or 3	150 (68)
PR 50-130 N	62 ¾ (158)	22 (56)	15 ¾ (40)	15 ¾ (40)	54 ½ (138)	55 (140)	6 ¾ (16)	6 ¾ (16)	1	½	2 or 3	176 (80)
PR 50-150 N	63 ¾ (162)	22 (56)	15 ¾ (40)	15 ¾ (40)	55 ¾ (142)	56 ¼ (143)	6 ¾ (16)	6 ¾ (16)	1	½	2 or 3	180 (82)
PR 50-175 N	63 ¾ (162)	22 (56)	15 ¾ (40)	15 ¾ (40)	55 ¾ (142)	56 ¼ (143)	6 ¾ (16)	6 ¾ (16)	1	½	3	180 (82)
PR 50-199 N	63 ¾ (162)	22 (56)	15 ¾ (40)	15 ¾ (40)	55 ¾ (142)	56 ¼ (143)	6 ¾ (16)	6 ¾ (16)	1	½	3	180 (82)

OPTIONAL KITS

Description	Part Number
2" Concentric vent kit	100093946
3" Concentric vent kit	100093947

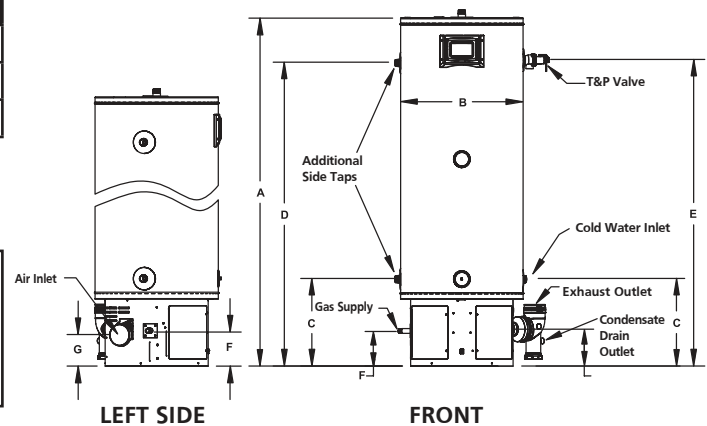
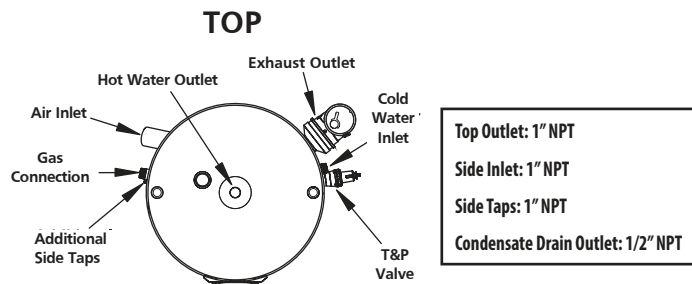

For Technical Information call 888-599-2837. A. O. Smith Enterprises Ltd. reserves the right to make product changes or improvements without prior notice.