

Cyclone™ XL

750,000 & 1,000,000 BTU/H High Efficiency, Condensing Water Heaters With Modulating Burner

Designed to provide years of dependable service, A. O. Smith Cyclone™ XL condensing water heaters feature industry-leading technology. Models are available from 750,000 & 1,000,000 Btu/h and all deliver thermal efficiencies of 97%. The primary and secondary heat exchangers provide optimal service life, while maximizing heat transfer.

Cyclone™ is the industry leader in high efficiency commercial water heating. Cyclone™ XL modulating models adjust firing rate to the specific demand further increasing efficiency and money savings.

INTELLIGENT CONTROL SYSTEM WITH TOUCH SCREEN DISPLAY AND ICOMM CONNECTIVITY ONBOARD*

- Exclusive A. O. Smith-designed color touch display control system
- Display provides detailed water heater status information
- Precise temperature control adjustable from 90 to 180 degrees
- Built-in diagnostics
- Run history information
- Cyclone™ XL comes standard with iCOMM Wi-Fi connectivity onboard. Remotely monitor and adjust the water heater via the A. O. Smith app. No charge connectivity using Wi-Fi or Ethernet connection.
- Intelligent Demand Response (IDR) feature senses large water draws and automatically adjusts the differential setpoint. This feature increases the hot water available when it is needed the most.

SUBMERGED COMBUSTION CHAMBER

- Positioned in center of tank, surrounded by water to virtually eliminate radiant heat loss from chamber
- Direct spark ignition
- Primary and secondary heat exchangers are constructed from stainless steel, with large surface areas to maximize heat transfer to the water
- Hot combustion gases from the primary heat exchanger pass through a secondary heat exchanger, raising efficiencies further, before the gases are vented.
- ASME construction

POWERED ANODES STANDARD ON ALL MODELS

- Provides long-lasting tank protection in varying water conditions
- Powered anodes are non-sacrificial
- Automatically adjusts output needed to properly protect the tank

PERMAGLAS® ULTRA COAT™ GLASS LINING

- Glass coating is applied using a liquid slush coating technique to ensure uniform coating
- Heat exchangers are glassed externally

MECHANICAL VENTING VERSATILITY

- Conventional power venting or direct venting
- Vents vertically or through a sidewall up to 100 eq. ft. (30.4m)
- Front-located exhaust and condensate connections allow for easy install and access
- Vents with low cost PVC Schedule 40 intake and exhaust pipe. Approved for optional CPVC Schedule 40, Polypropylene and AL29-4C stainless steel vent materials
- Canadian installations require ULC S636 PVC/CPVC, ULC S636 Polypropylene or AL29-4C stainless steel pipe for venting

HIGH EFFICIENCY MODULATING PRE-MIX POWERED BURNER

- Down-fired pre-mix burner provides optimum efficiency and quiet operation
- Top-mounted burner position prevents condensation from affecting burner operation

5-YEAR LIMITED TANK / 1-YEAR LIMITED PARTS WARRANTY

- For complete warranty information, consult written warranty or go to hotwatercanada.ca



**BTHS-750A AND BTHS-1000A
MODEL SHOWN:
BTHS-1000A SERIES 100/101**





Commercial Gas Water Heaters

OTHER FEATURES:

SPACE-SAVING DESIGN FOR INSTALLATION FLEXIBILITY

- Large volume, integrated solution extends the Cyclone™ high-efficiency, condensing water heater line to 1,000,000 BTU/H
- Easy-to-remove top cover for convenient access to serviceable parts
- 0" installation clearances on sides and rear, 1-1/2" installation clearance on top
- Handhole cleanout allows easy access to tank interior for cleaning
- 0" clearance to combustibles, approved for installation on combustible floors

CODES AND STANDARDS

- CSA-certified and ASME-rated T&P relief valve
- Maximum hydrostatic working pressure: 160 psi
- All models are design certified by Underwriters Laboratories (UL), Inc., to ANSI Z21.10.3 - CSA 4.3 Standards
- Meets the thermal efficiency and standby loss requirements of Natural Resources Canada (NRCan)
- Design certified by Underwriters Laboratories to NSF 5 for 180°F (82°C) water
- Complies with SCAQMD Rule 1146.2 and other Air Quality Management Districts with similar requirements for ultra low-NOx emissions
- ASME tank construction standard on all models

VENT REQUIREMENTS FOR BTHS 750A - 1000A

| NUMBER OF 90° ELBOWS INSTALLED | 6 INCH PIPE |
|--------------------------------|-----------------------|
| | MAXIMUM FEET (METERS) |
| One (1) | 95 feet (28.9 meters) |
| Two (2) | 90 feet (27.4 meters) |
| Three (3) | 85 feet (25.9 meters) |
| Four (4) | 80 feet (24.3 meters) |
| Five (5) | 75 feet (22.8 meters) |
| Six (6) | 70 feet (21.3 meters) |

GAS PRESSURE REQUIREMENTS

| MODEL NUMBER | * MANIFOLD PRESSURE | | MINIMUM SUPPLY PRESSURE | | MAXIMUM SUPPLY PRESSURE | |
|--------------|---------------------|-----------------|-------------------------|--------------------|-------------------------|---------------------|
| | NATURAL GAS | PROPANE GAS | NATURAL GAS | PROPANE GAS | NATURAL GAS | PROPANE GAS |
| BTHS-750A | 0" W.C. (0 kPa) | 0" W.C. (0 kPa) | 3.5" W.C. (0.87 kPa) | 8" W.C. (1.99 kPa) | 14" W.C. (3.49 kPa) | 14" W.C. (3.49 kPa) |
| BTHS-1000A | 0" W.C. (0 kPa) | 0" W.C. (0 kPa) | 3.5" W.C. (0.87 kPa) | 8" W.C. (1.99 kPa) | 14" W.C. (3.49 kPa) | 14" W.C. (3.49 kPa) |

* The manifold pressure is the factory setting and is not adjustable. A negative pressure will be seen with just the blower running without the Gas Control Valve open.

GAS LINE CONNECTION SIZE

| MODEL NUMBER | SERIES | NATURAL GAS | PROPANE GAS |
|--------------|---------|-------------|-------------|
| BTHS-750A | 100/101 | 2" NPT | 2" NPT |
| BTHS-1000A | 100/101 | 2" NPT | 2" NPT |

Depending on the installed equivalent length and/or the number of appliances connected, the supply gas line size may need to be increased beyond the minimum size requirement.

BTHS 750A - 1000A

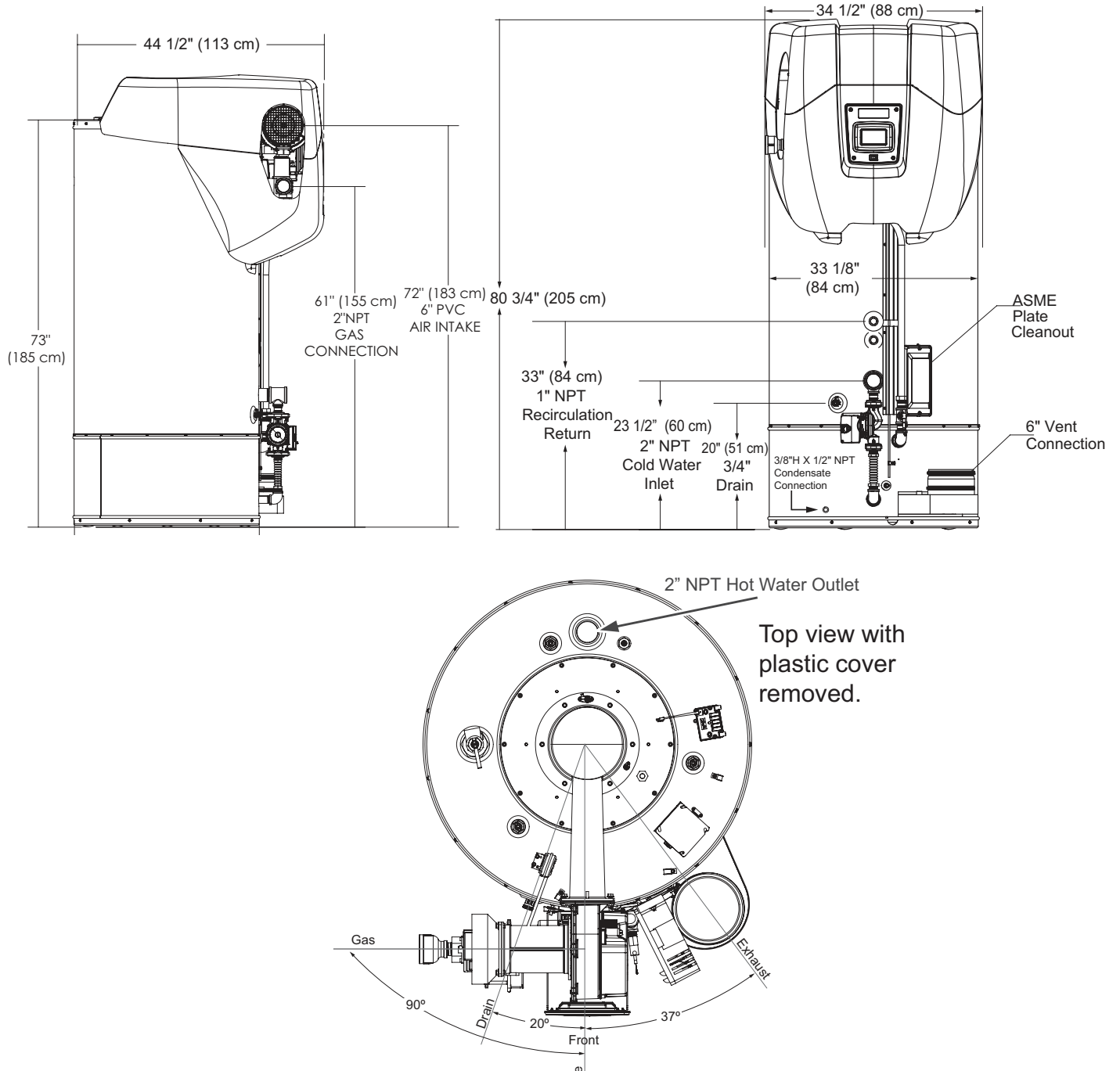

Electrical characteristics-120V-60Hz A.C., 5.0 A

"A" in model represents ASME construction

Propane gas models available

Dimensions and specifications subject to change without notice in accordance with our policy of continuous product improvement.

RECOVERY CAPACITY

| MODEL NUMBER | TYPE OF GAS | INPUT | | THERMAL EFFICIENCY |
|--------------|-----------------|-----------|-----|--------------------|
| | | BTU/hr | kW | |
| BTHS-750A | Natural/Propane | 750,000 | 220 | 97% |
| BTHS-1000A | Natural/Propane | 1,000,000 | 293 | 97% |

| MODEL NUMBER | U.S. GALLONS AND LITRES/HR AT TEMPERATURE RISE INDICATED | | | | | | | | | | | | | |
|--------------|--|-----|--------|--------|-------|-------|-------|-------|-------|--------|--------|--------|--------|--------|
| | APPROX. CAPACITY | °F | 30° F | 40° F | 50° F | 60° F | 70° F | 80° F | 90° F | 100° F | 110° F | 120° F | 130° F | 140° F |
| | | °C | 17° C | 22° C | 28° C | 33° C | 39° C | 44° C | 50° C | 56° C | 61° C | 67° C | 72° C | 78° C |
| BTHS-750A | 120 U.S. Gals. | GPH | 2,940 | 2,205 | 1,764 | 1,469 | 1,260 | 1,103 | 979 | 882 | 802 | 734 | 678 | 630 |
| | 454 Liters | LPH | 11,129 | 8,347 | 6,677 | 5,561 | 4,770 | 4,175 | 3,706 | 3,339 | 3,036 | 2,778 | 2,567 | 2,385 |
| BTHS-1000A | 120 U.S. Gals. | GPH | 3,920 | 2,940 | 2,352 | 1,960 | 1,680 | 1,470 | 1,307 | 1,176 | 1,069 | 980 | 905 | 839 |
| | 454 Liters | LPH | 14,839 | 11,129 | 8,903 | 7,419 | 6,359 | 5,565 | 4,948 | 4,452 | 4,047 | 3,710 | 3,426 | 3,176 |

Recovery capacities are based on AHRI rated thermal efficiencies.

STORAGE CAPACITY AND WEIGHT

| MODEL NUMBER | U.S. GALLONS | LITERS | APPROX. SHIPPING WEIGHT LB (KG) |
|--------------|--------------|--------|---------------------------------|
| BTHS-750A | 120 | 454 | 1300 (590) |
| BTHS-1000A | 120 | 454 | 1300 (590) |

OPTIONAL KITS

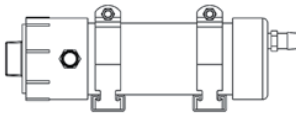

OPTIONAL CONDENSATE NEUTRALIZATION KITS

- BTHS 750A kit 100289340
- BTHS 1000A kit 100289581

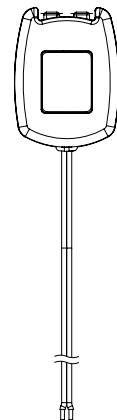

OPTIONAL LEAK DETECTION KIT

- BTHS-750A - 1000A kit 100302557

SPECIFICATION

(Natural or Propane) gas water heater(s) shall be A. O. Smith Cyclone™ XL model # _____ or equal, with minimum 97% thermal efficiency, storage capacity of 120 US gallons, an input rating of _____ BTU/h, a recovery rating of _____ gallons per hour (gph) at 100°F rise, and a maximum hydrostatic working pressure of 160 psi.

Water heater(s) shall: 1. Have a modulating down-fired gas power burner designed for precise mixing of air and gas for optimum efficiency, requiring no special calibration on start-up, and that automatically adjusts the input based on demand. 2. Have an integrated solid-state temperature and ignition control with graphical user interface, integral diagnostics, fault history, temperature and operating status. No-charge connectivity shall be provided allowing for remote monitoring and fault notification via app. 3. Have powered anodes that are non-sacrificial and maintenance-free. 4. Have an ASME-certified steel tank with seamless glass lining applied to all water-side surfaces after the tank has been assembled and welded. 5. Have foam insulation and include a CSA-certified and ASME-rated T&P relief valve. 6. Be approved for 0" clearance to combustibles.

All models are design certified by Underwriters Laboratories (UL), Inc., according to ANSI Z21.10.3 - CSA 4.3 standards governing storage type water heaters; and meet the thermal efficiency and standby loss requirements of Natural Resources Canada (NRCAN) and current edition ASHRAE/IES 90.1. Complies with SCAQMD Rule 1146.2 and other air quality management districts with similar requirements for low NOx emissions.

750,000 & 1,000,000 BTU/h Input: For Standard Power Venting: Water heater(s) shall be suitable for standard power venting using 6" diameter ULC S636 pipe up to 100 equivalent feet of vent piping. For Power Direct Venting: Water heater(s) shall be suitable for power direct venting using 6" diameter ULC S636 pipe up to 100 equivalent feet of vent piping and 100 equivalent feet of intake air piping.

Operation of the water heater(s) in a closed system where no provisions for thermal expansion have been made (with a properly sized thermal expansion tank) will void the warranty.

For Technical Information call 888-599-2837. A. O. Smith Enterprises Ltd. reserves the right to make product changes or improvements without prior notice.