

### VOLTEX® AL SMART HYBRID ELECTRIC HEAT PUMP WATER HEATER WITH ANTI-LEAK TECHNOLOGY

The Voltex® AL Smart Hybrid Electric heat pump water heater from A. O. Smith is the most cost-effective, energy-efficient option available for consumers who want to save money on their utility bills. Voltex® AL combines annual savings on utility bills with new leak protection features to support homeowner peace of mind like leak detection and optional automatic water shutoff.

#### HOW DO THEY WORK?

Absorb ambient heat from the surrounding air to heat water using a compressor

- Self-contained heat pump unit is integrated into the top of the tank
- Backup electric elements can supplement the heat pump depending on operating mode, environmental conditions and hot water demand

#### EXCEPTIONAL ENERGY EFFICIENCY

- Improved efficiency up to 3.88 Uniform Energy Factor (UEF) can reduce the cost of water heating by up to 75%\*
- Heat pump can work down to 2°C (37°F) ambient for more days of high efficiency operation
- ENERGY STAR® certified for many state and local utility rebates

#### iCOMM™ SMART CONNECTIVITY

- Monitor and control your water heater through the free A. O. Smith app
- Connect through a local Wi-Fi network or directly to the water heater through Bluetooth®
- If applicable download the Time of Use schedule of your local electric utility to prioritize heating when the rates are most affordable
- Receive alerts and notifications

#### LEAK PROTECTION TECHNOLOGY

- Smart anode adapts to local water conditions to protect and extend the life of the water heater
- Controls regulate depletion of the anode to extend the life of the anode allowing superior tank protection far longer than standard anode rods
- User is notified when the anode is consumed and needs to be replaced
- Smart sensor alerts user in the event a leak does occur for added peace of mind

- Compatible with the automatic water shutoff valve for enhanced protection (accessory kit 100345338)
- Notifications through iCOMM function on the A. O. Smith app

#### QUIET OPERATION

- Whisper-quiet operation at 45 dBA

#### FLEXIBLE DESIGN

- Top and front water connections for easy installation
- Zero clearance required on sides and back to fit in tighter spaces
- Integrated ducting adapters for installations in confined spaces
- Ideal for basements, utility rooms or garage installations; the compressor transfers heat to the water while dehumidifying and cooling the ambient air

#### ELECTRONIC CONTROLS

- User-friendly electronic interface allows easy control of temperature, operating mode and diagnostics

#### 10-YEAR LIMITED WARRANTY

- For complete information, consult written warranty or go to [hotwatercanada.com](http://hotwatercanada.com)



\*Comparing 80-gallon Voltex® AL heat pump against pre-2015 similarly-sized standard electric using DOE EF to UEF conversion rates and \$0.14 per kWh electricity cost. Savings may vary.

Model Number	Nominal Capacity	Rated Storage Volume	UEF	First Hour Rating (gallons)	Dimensions in Inches							Approx Shipping Weight (lbs)	Warranty Term
					A	B	C	D	E	F	G		
HPTS-50	50	46	3.80	65	63	22	40.5	3.75	8	43.5	48	196	10
HPTS-66	66	67	3.70	82	61.5	26.5	38.25	4	8	41.25	46	284	10
HPTS-80	80	82	3.88	95	69	26.5	46.5	4	8	50.5	54.5	302	10

Requires 30 amp breaker.

### MULTIPLE OPERATING MODES

Choose from multiple modes to match water heating needs and environmental conditions

- Hybrid (Default): Hot water delivery balanced with energy saving performance
- Heat Pump: Maximum energy efficiency
- Electric: Uses only the electric heating elements
- Vacation: Reduce energy use while you are away

### iCOMM™ SMART CONNECTIVITY

Download the free A. O. Smith app to get started.



### OTHER FEATURES:

- Easily accessible front mounted junction box
- Environmentally-friendly, non-CFC foam insulation
- Durable, enhanced-flow brass drain valve
- CSA certified and ASME rated temperature & pressure relief valve

### OPERATING REQUIREMENTS:

- Requires provision for non-acidic condensate draining; if a suitable drain is not available a condensate pump is required
- 208/240 VAC 50/60Hz single phase 30 amp power supply

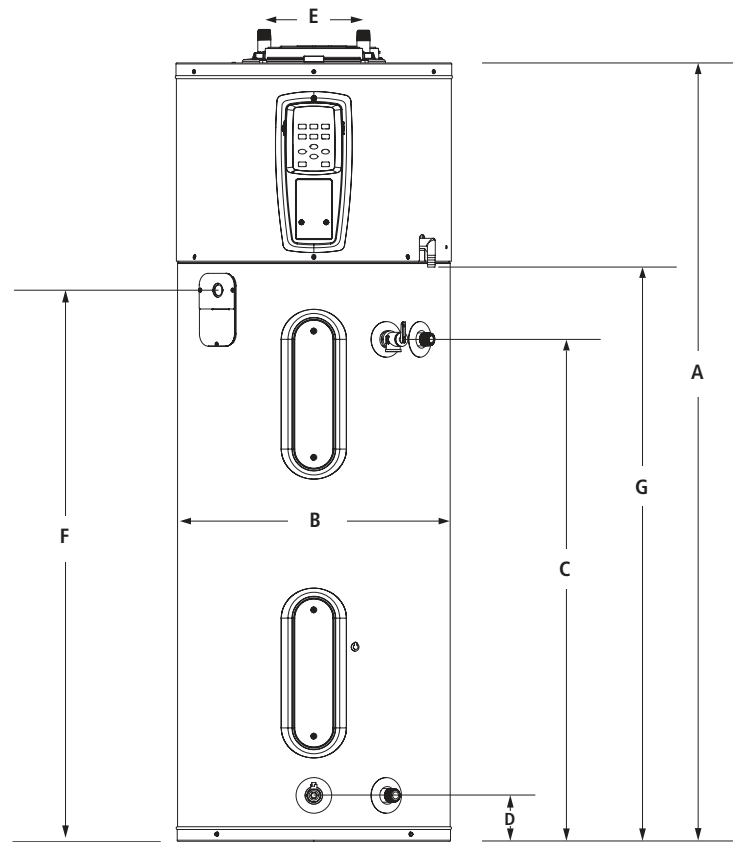

Apple logo and Apple App Store Logo are trademarks of Apple Inc.  
Google Play and the Google Play logo are trademarks of Google LLC.

For Technical Information, call 800-527-1953. A. O. Smith Corporation reserves the right to make product changes or improvements without prior notice.