

## ProLine® XE POWER DIRECT VENT

### ENERGY SAVINGS

- Exceeds NRCan energy efficiency standards
- Factory-installed heat trap nipples

### DESIGNED FOR PERFORMANCE

- ProLine® XE are residential water heaters with commercial grade quality
- Compact design – ideal as a replacement water heater and for closet installations
- Ultra-quiet blower
- Convenient 3/4" side water connections for combination applications on high input 50 USG and 75 USG units (plugs are factory-installed)
- Suitable for altitudes up to 10,100 ft. (3,078 m)
- Factory-installed T&P valve and drip tube
- Blue Diamond® glass coating protects steel tank from corrosion and maximizes tank life

### SAFETY FEATURES

- Sealed combustion chamber design, eliminating the need for a flammable vapour sensor
- Zero clearance to combustibles

### SERVICEABILITY

- State-of-the-art gas control features advanced self diagnostic capability that makes troubleshooting easy
- Conveniently located T&P and drain valve for ease of serviceability
- Auto-reset temperature switch monitors vent temperature

### THE ULTIMATE IN VENTING FLEXIBILITY

- Can be vented with 2", 3" or 4" ULC S636 PVC, CPVC or polypropylene pipe up to 180 equivalent feet (see installation manual for full details)
- Can be installed using a concentric vent kit (see reverse or installation manual for details)

### WARRANTY

- 6 year limited tank and parts warranty
- 2 or 4 year tank warranty extension kits available

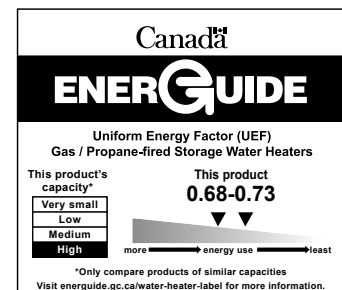

## PERFORMANCE

MODEL	SERIES	CAPACITY	INPUT	RECOVERY RATE AT 90°F TEMPERATURE RISE	FIRST HOUR RATING	UEF	WARRANTY TANK/PARTS
		USG (L)	BTU/h	GPH (LPH)	USG (L)		YEARS
<b>NATURAL GAS</b>							
GPDL 40	300/301	40 (151)	40,000	44 (167)	71 (269)	0.68	6/6
GPDT 50	300/301	50 (189)	45,000	50 (189)	93 (352)	0.72	6/6
GPDX 50L*	300/301	50 (189)	62,000	67 (254)	100 (379)	0.73	6/6
GPDX 75L*	300/301	75 (284)	72,000	82 (310)	154 (583)	0.68	6/6

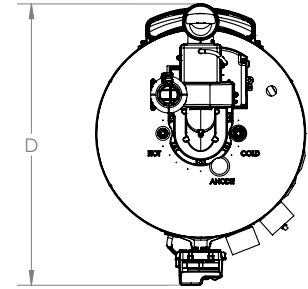

All models rated for installation at altitudes up to 10,100 ft (3,078 m).

Natural gas models are series 300. Propane models are series 301. All models comply with national energy efficiency regulations.

\*Side connections.

## DIMENSIONS & SHIPPING WEIGHT

MODEL	INSTALLATION HEIGHT	HEIGHT TO TOP OF TANK	TANK DIAMETER	OVERALL DEPTH	HEIGHT TO DRAIN VALVE	HEIGHT TO GAS INLET	HEIGHT TO T&P	HEIGHT TO UPPER SIDE CONNECTION	HEIGHT TO LOWER SIDE CONNECTION	VENT DIAMETER	SHIPPING WEIGHT
	A IN (CM)	B IN (CM)	C IN (CM)	D IN (CM)	E IN (CM)	F IN (CM)	G IN (CM)	G IN (CM)	H IN (CM)	IN	LB (KG)
<b>NATURAL GAS</b>											
GPDL 40	58 ¼ (148)	49 ½ (126)	22 (56)	29 7/8 (76)	11 (28)	13 ¼ (34)	42 5/8 (108)	N/A	N/A	2, 3 or 4	174 (79)
GPDT 50	67 ½ (171)	58 7/8 (150)	22 (56)	29 7/8 (76)	11 (28)	13 ¼ (34)	51 ¾ (131)	N/A	N/A	2, 3 or 4	192 (87)
GPDX 50L	68 7/8 (175)	60 ¼ (153)	22 (56)	29 7/8 (76)	11 (28)	13 ¼ (34)	52 ¾ (134)	52 ¾ (134)	15 ¼ (39)	3 or 4	200 (91)
GPDX 75L	70 5/8 (179)	60 ½ (154)	26 (66)	33 7/8 (86)	11 (28)	13 ¼ (34)	53 (135)	53 (135)	15 ¼ (39)	3 or 4	277 (126)

## VENT PIPE LENGTHS

MODEL	VENT PIPE DIAMETER IN	MINIMUM NUMBER OF ELBOWS REQUIRED*	MINIMUM VENT LENGTH WITH ONE ELBOW FT (M)		MAXIMUM EQUIVALENT VENT LENGTH FT (M)		
			CONCENTRIC	2 PIPE	CONCENTRIC	2 PIPE	
			GPDL 40	2	1	7 (2)	7 (2)
GPDL 40	3	1	7 (2)	7 (2)	100 (30)	125 (38)	
	4	1	N/A	50 (15)	N/A	180 (55)	
	GPDT 50	2	1	7 (2)	7 (2)	50 (15)	50 (15)
GPDT 50	3	1	7 (2)	7 (2)	100 (30)	125 (38)	
	4	1	N/A	50 (15)	N/A	180 (55)	
	GPDX 50L	3	1	7 (2)	7 (2)	45 (14)	50 (15)
GPDX 50L	4	1	N/A	50 (15)	N/A	125 (38)	
	GPDX 75L	3	1	7 (2)	7 (2)	30 (9)	50 (15)
	4	1	N/A	50 (15)	N/A	125 (38)	

\*Refer to installation manual for further details.

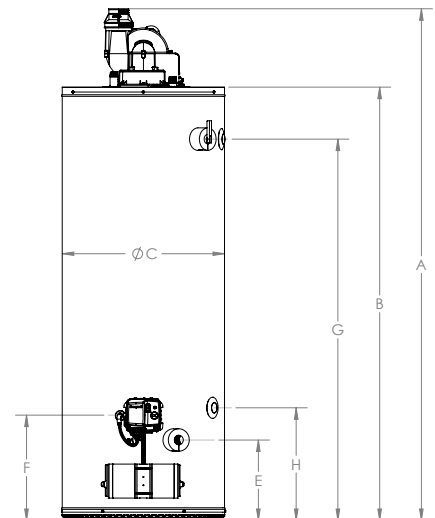

## OPTIONAL KITS

DESCRIPTION	PART NUMBER
2" concentric vent kit	100112869
3" concentric vent kit	100111100
High ambient kit	100308923

For Technical Information call 888-599-2837. A. O. Smith Enterprises Ltd. reserves the right to make product changes or improvements without prior notice.