

# On-Demand Water Heater Installation Manual and Owner's Guide

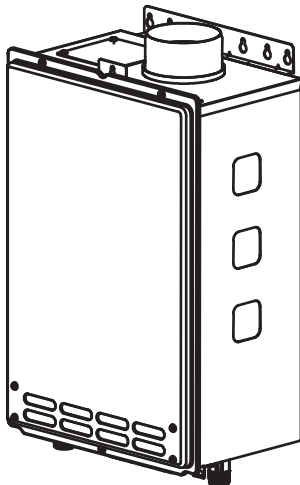

510 model  
only



## Gas Tankless Water Heater™

*Suitable for potable water heating and space-heating\**

*\* Please refer to local codes for space-heating compliance.*

### FEATURING

- ENDLESS HOT WATER
- ON-DEMAND USAGE
- COMPACT, SPACE SAVING
- ENERGY CONSERVATION
- COMPUTERIZED SAFETY
- NO PILOT LIGHT
- EASY-LINK SYSTEM\*

\*(510 models only)

## Models

- 110
- 310
- 510



**WARNING**

If the information in these instructions is not followed exactly, a fire or explosion may result causing property damage, personal injury or death.

- Do not store or use gasoline or other flammable vapors and liquids in the vicinity of this or any other appliance.
- WHAT TO DO IF YOU SMELL GAS
  - Do not try to light any appliance.
  - Do not touch any electric switch, do not use any phone in your building.
  - Immediately call your gas supplier from a neighbor's phone. Follow the gas supplier's instructions.
  - If you cannot reach your gas supplier, call the fire department.
- Installation and service must be performed by a qualified installer, service agency or the gas supplier.

If you have any questions,  
please call or write to:  
GSW Water Heating  
599 Hill Street West  
Fergus, ON Canada N1M 2X1  
Toll Free: 1-888-479-8324

# Table of Contents

SPECIFICATIONS .....	3	TROUBLESHOOTING .....	28
INTRODUCTION .....	4	General .....	28
SAFETY GUIDELINES .....	4	Error Codes .....	30
Safety Definitions .....	4	Single Unit Installations	
General .....	4	Easy-Link System	
INSTALLATION .....	5	Fault Analysis Of Error Codes .....	31
General .....	5	COMPONENTS DIAGRAM .....	34
Clearances .....	7	Case Assembly .....	34
Included Accessories .....	7	110	
Optional Items .....	7	310 & 510	
High-altitude Installations .....	10	Burner Assembly .....	35
Venting Instructions .....	10	110	
General		310 & 510	
Exhaust venting		Computer Board Assembly .....	37
Venting Illustrations		110 & 310	
Vent Termination Clearances		Water Way Assembly .....	37
Gas supply and gas pipe sizing .....	15	110	
General		Computer Board Assembly .....	37
Gas Connections		510	
Measuring Inlet Gas Pressure		Water Way Assembly .....	37
Water Connections .....	15	310	
Pressure Relief Valve		Water Way Assembly .....	38
Electrical Connections .....	16	510	
Remote Controller Connections .....	17	Water outlet section .....	38
Pump Control Mode .....	18	Water inlet section .....	38
Easy-link System .....	18	PARTS LIST .....	39
General		OUTPUT TEMPERATURE CHART .....	41
Easy-Link Connection Procedures		110 Models	
APPLICATIONS .....	20	310 Models	
Space-Heating Applications .....	20	510 Models	
Recirculation .....	21	LIMITED WARRANTY .....	42
Dual-purpose Hot Water Heating .....	21		
INITIAL OPERATION .....	22		
OPERATING SAFETY .....	23		
NORMAL OPERATION .....	25		
General .....	25		
Temperature Settings .....	25		
Without Remote Controller			
Dipswitch Settings For Temperature			
Flow .....	26		
Freeze protection system .....	26		
Maintenance and service .....	27		
Unit Draining and Filter Cleaning			

## SPECIFICATIONS

Model		110	310	510
Natural Gas Input (Operating Range)		Min.: 19,500 BTU/h Max.: 140,000 BTU/h	Min.: 11,000 BTU/h Max.: 190,000 BTU/h	Min.: 11,000 BTU/h Max.: 199,000 BTU/h
Propane Input (Operating Range)		Min.: 19,500 BTU/h Max.: 140,000 BTU/h	Min.: 11,000 BTU/h Max.: 190,000 BTU/h	Min.: 11,000 BTU/h Max.: 199,000 BTU/h
Gas Connection		3/4" NPT		
Water Connections		3/4" NPT		
Water Pressure		15 - 150 psi*		
Inlet Pressure	Natural Gas	Min. 5.0" WC, Max. 10.5" WC		
	Propane	Min. 8.0" WC, Max. 14.0" WC		
Manifold Pressure**	Natural Gas	2.0" WC	2.0" WC	2.0" WC
	Propane	2.5" WC	3.7" WC	3.7" WC
Weight		13Kg (28.7 lbs.)	15.7Kg (34.6 lbs.)	
Dimensions		520mm(H) x 351mm(W) x 170mm(D) H20.5" x W13.8" x D6.7"	520mm(H) x 351mm(W) x D216mm(D) H20.5" x W13.8" x D8.5"	
Ignition		Electric Ignition		
Electric Consumption	Supply	120 VAC, 60 Hz		
	Operation	73.1 W / 0.61 A	87.6 W / 0.73 A	89.8 W / 0.75 A
	Standby	6.2 W / 0.05 A	6.2 W / 0.05 A	6.2 W / 0.05 A
	Freeze-Protection	111 W / 0.93 A	111 W / 0.93 A	111 W / 0.93 A
<p>* 40 psi or above is recommended for maximum flow.</p> <p>** The Manifold Pressure is the factory setting and generally should not need adjustment.</p> <p>NOTE:</p> <ul style="list-style-type: none"> <li>• Check the rating plate to ensure this product matches your specifications.</li> <li>• The manufacturer reserves the right to discontinue, or change at any time, specifications or designs without notice and without incurring obligations.</li> </ul>				

## INTRODUCTION

- This manual provides information necessary for the installation, operation, and maintenance of the water heater.
- The model description is listed on the rating plate which is attached to the front panel of the water heater.
- Please read all installation instructions completely before installing this product.
- If you have any problems or questions regarding this equipment, consult with the manufacturer or its local representative.
- This equipment is an on-demand, tankless water heater designed to efficiently supply endless hot water for your needs.
- The 110, 310, & 510 models are to be installed indoors only (direct-vent convertible).
- The principle behind tankless water heaters is simple:

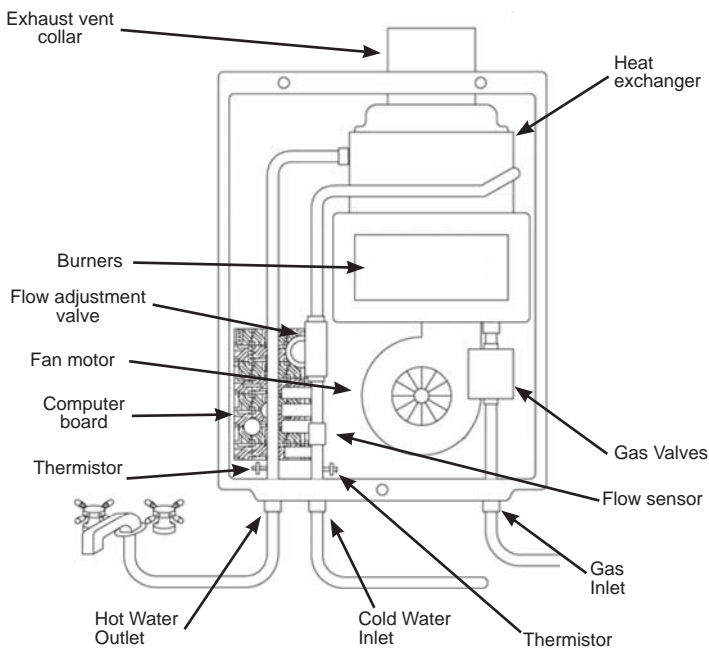

\* This diagram illustrates tankless water heater design concepts only and does not accurately represent to the water heater's physical description.

1. A hot water tap is turned on.
2. Water enters the heater.
3. The water flow sensor detects the water flow.
4. The computer initiates the fan motor and sends a signal to the igniter to create an ignition spark.
5. The gas ignites and flames appear within the burner chamber.
6. Water circulates through the heat exchanger and then gets hot.
7. Using thermistors to measure temperatures throughout the water heater, the computer modulates the gas and water valves to ensure proper output water temperature.

## SAFETY GUIDELINES

### Safety Definitions



**DANGER**

Indicates an imminently hazardous situation which, if not avoided, will result in death or serious injury.



**WARNING**

Indicates an imminently hazardous situation which, if not avoided, could result in death or serious injury.



**CAUTION**

Indicates an imminently hazardous situation which, if not avoided, could result in minor or moderate injury.

### General

1. Follow all local codes, or in the absence of local codes, follow the most recent edition of **CSA B149.1 Natural Gas and Propane Installation Code**.
2. Properly ground the unit in accordance with all local codes or in the absence of local codes, with **CSA C22.1 Canada Electrical Code Part 1**.
3. Carefully plan where you intend to install the water heater. Please ensure:
  - Your water heater will have enough combustible air and proper ventilation.
  - Locate your heater where water leakage will not damage surrounding areas (please refer to pg. 6).
4. Check the rating plate for the correct **GAS TYPE, GAS PRESSURE, WATER PRESSURE and ELECTRIC RATING**.
  - \* If this unit does not match your requirements, do not install. Consult with the manufacturer.
5. If any problem should occur, turn off all hot water taps and turn off the gas. Then call a trained technician or the Gas Company or the manufacturer.



**WARNING**

- Water temperatures over 52°C (125°F) can cause severe burns instantly or death from scalding. The water temperature is set at 50°C (122°F) from the factory to minimize any scalding risk. Before bathing or showering always check the water-temperature.
- Do not store or use gasoline or other flammables, vapors, or liquids in the vicinity of this appliance.
- Do not reverse the water and/or gas connections as this will damage the gas valves and can cause severe injury or death. Follow the diagram on pg. 17 when installing your water heater.
- Do not use this appliance if any part has been in contact with or been immersed in water. Immediately call a licensed plumber, a licensed gas fitter, or a professional service technician to inspect and/or service the unit if necessary.
- Do not disconnect the electrical supply if the ambient temperature will drop below freezing. The Freeze Prevention System only works if the unit has electrical power. The warranty will not be covered if the heat exchanger is damaged due to freezing. Refer to the section on the Freeze Prevention System on pg. 28 for more information.

8. Particles from flour, aerosols, and other contaminants may clog the air vent or reduce the functions of the rotating fan and cause improper burning of the gas. Regularly ensure that the area around the unit is dust- or debris-free; regular maintenance is recommended for these types of environment.
9. If you will be installing the water heater in a contaminated area with a high level of dust, sand, flour, aerosols or other contaminants/chemicals, they can become airborne and enter and build up within the fan and burner causing damage to the water heater.
10. For the 110, 310, & 510 models:
  - These units may be converted to a direct-vent (sealed combustion) appliance by installing a direct-vent conversion kit (Part No. TK-TV10) which will bring in all required combustible air from outside the building. When installing the direct-vent conversion kit, please follow all instructions included with the kit.
  - If the water heater is used as a direct-vent appliance, the unit requires a 76mm (3 in.) combustible air supply pipe. The intake pipe must be sealed airtight. Air supply pipe can be made of ABS, PVC, galvanized steel, corrugated aluminum, corrugated stainless steel or Category III stainless steel.
  - Terminating the venting through a sidewall is recommended for the direct-vent system.
  - Running the exhaust vent and the intake pipe parallel is recommended.
  - Terminating the exhaust and intake on the same wall/surface is recommended. Terminating in the same pressure zone allows for pressure balancing, which prevents nuisance shutdowns.

## INSTALLATION

### General

1. Follow all local codes, or in the absence of local codes, follow the most recent edition of **CSA B149.1 Natural Gas and Propane Installation Code**.
2. All gas water heaters require careful and correct installation to ensure safe and efficient operation. This manual must be followed exactly. Read the "Safety Guidelines" section.
3. The manifold gas pressure is preset at the factory. It is computer controlled and should not need adjustment.
4. Maintain proper space for servicing. Install the unit so that it can be connected or removed easily. Refer to the "Clearances" section on pg. 7 for proper clearances.
5. The water heater must be installed in a location where the proper amount of combustible air will be available to it at all times without obstructions.
6. The electrical connection requires a means of disconnection, to terminate power to the water heater for servicing and safety purposes.
7. Do not install the unit where the exhaust vent is pointing into any opening in a building or where the noise may disturb your neighbors. Make sure the vent termination meets the required distance by local code from any doorway or opening to prevent exhaust from entering a building (refer to pg. 13).



**WARNING**

- Installation and service must be performed by a qualified installer (for example, a licensed plumber or gas fitter), otherwise the warranty will be void.
- The installer (licensed professional) is responsible for the correct installation of the water heater and for compliance with all national, state/provincial, and local codes.
- The manufacturer does not recommend installing the water heater in a pit or location where gas and water can accumulate.
- Do not have the vent terminal pointing toward any operating window, door, or opening into a building.
- Do not install next to any source of airborne debris, such as a clothes dryer, that can cause debris to be trapped inside the combustion chamber, unless the system is direct-vented.
- **The manufacturer does not recommend installing the water heater in an attic due to safety issues.** If you install the water heater in an attic:
  - Make sure the unit will have enough combustion air and proper ventilation.
  - Keep the area around the water heater clean. When dust collects on the flame sensor, the water heater will shut down on an error code.
  - If the above conditions cannot be met, use the direct vent conversion kit TK-TV10.
  - Place the unit for easy access for service and maintenance.
  - A drain pan, or other means of protection against water damage, is required to be installed under the water heater in case of leaks.



**CAUTION**

- **The warranty will not cover damage caused by water quality.**
  - Only potable water or potable water/glycol mixtures can be used with this water heater. Do not introduce pool or spa water, or any chemically treated water into the water heater.
  - Water hardness levels must not exceed 7 grains per gallon (120 ppm) for single family domestic applications or more than 4 grains per gallon (70 ppm) for all other types of applications. Water hardness leads to scale formation and may affect/damage the water heater. Hard water scaling must be avoided or controlled by proper water treatment.
  - Water pH levels must be between 6.5 and 8.5
  - Well water must be treated.
- Do not install the unit where water, debris, or flammable vapors may get into the flue terminal.
- **The manufacturer recommends using the direct vent kit when the water heater is installed in a beauty salon.** Some chemicals used in a beauty salon may affect the flame sensor. Water heater may not work properly.
- Although the water heater is designed to operate with minimal sound, **the manufacturer does not recommend installing the unit on a wall adjacent to a bedroom, or a room that is intended for quiet study or meditation, etc.**
- Locate your heater close to a drain where water leakage will not do damage to surrounding areas. As with any water heating appliance, the potential for leakage at some time in the life of the product does exist. The manufacturer will not be responsible for any water damage that may occur. If you install a drain pan under the unit, ensure that it will not restrict the combustion air flow.

## Clearances

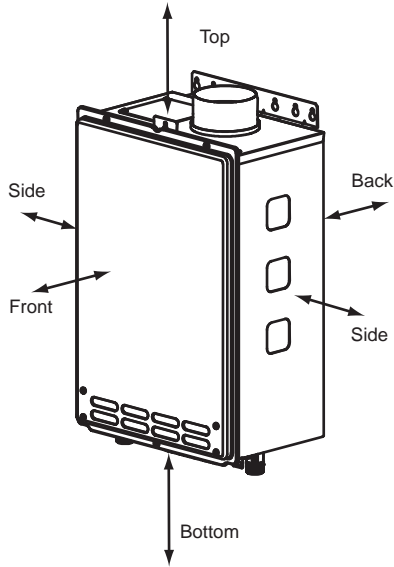



Maintain all clearances around the water heater.



## Optional Items

Model	110	310	510
TK-RE02	x	x	
TM-RE30			x
TK-BF01	x	x	x
TK-TV10	x	x	x
TK-PC01		x	x
TK-PCJr2	x		
TK-KPWL4	x	x	x
TK-KPWH4	x	x	x
TK-KPCT43	x	x	x

Model	Top	Bottom	Front	Back	Sides
110	305mm (12 in.)	305mm (12 in.)	610mm (24 in.)	25mm (1 in.)	51mm (2 in.)
310	305mm (12 in.)	305mm (12 in.)	610mm (24 in.)	25mm (1 in.)	51mm (2 in.)
510	305mm (12 in.)	305mm (12 in.)	610mm (24 in.)	25mm (1 in.)	51mm (2 in.)

## Included Accessories

Check that these items below are included with the water heater.

Items		
Installation Manual & Owner's Guide		Qty: 1
Product Registration Card		Qty: 1
Communication Cable (510 models only)		Qty: 1



1. Temperature Remote Controller: TK-RE02



The Temperature Remote Controller has two functions. It allows the output temperature from the water heater to be adjusted within the range of 37°C to 75°C (99°F to 167°F), and it also works as a diagnostic tool that will give a concise error code whenever there is a problem with the unit. The temperature options are 75°C (99°F), 38°C (100°F), 39°C (102°F), 40°C (104°F), 41°C (106°F), 42°C (108°F), 43°C (109°F), 44°C (111°F), 45°C (113°F), 46°C (115°F), 47°C (117°F), 50°C (122°F), 55°C (131°F), 60°C (140°F), 70°C (158°F), and 75°C (167°F). See the troubleshooting section for information on possible error codes.

2. Temperature Remote Controller: TM-RE30



The Temperature Remote Controller has two functions. It allows the output temperature from the water heater to be adjusted within the range of 37°C to 85°C (99°F to 185°F), and it also works as a diagnostic tool that will give a concise error code whenever there is a problem with the unit. The temperature options are 75°C (99°F), 38°C (100°F), 39°C (102°F), 40°C (104°F), 41°C (106°F), 42°C (108°F), 43°C (110°F), 44°C (111°F), 45°C (113°F), 46°C (115°F), 47°C (117°F), 50°C (122°F), 55°C (131°F), 60°C (140°F), 65°C (149°F), 70°C (158°F), 75°C (167°F), 80°C (176°F) and 85°C (185°F). See the troubleshooting section for information on possible error codes.

3. Backflow Preventer: TK-BF01



The Backflow preventer prevents the backflow of air through the exhaust vent. This helps prevent harmful exhaust gases from entering the home, as well as helping to prevent the unit from freezing in areas where cold air can be blown or drawn into the exhaust system. Install this vent damper in accordance with the installation instructions and any applicable codes.

4. Direct-Vent Conversion Kit: TK-TV10



This kit can be used to convert the water heater from a standard vent system to a direct-vent (or sealed combustion) system. Install this conversion kit in accordance with the installation instructions and any applicable codes.

5. Pipe Covers: TK-PC01 and TK-PCJr2



The pipe cover protects the plumbing pipes to the water heater from unexpected adjustments. This pipe cover is fixed to the bottom of the water heater, which hides the plumbing and improves the visual aspects of the whole installation for the water heater.



6. Recess box: TK-RB02



The Recess box will allow for “clean” installations. The water heater fits inside the recess box, which hides and protects the whole water heater and plumbing. The Recess box will fit in-between most wall studs.

7. T-Vent Wall Thimble with Termination: TK-KPWL4 and TK-KPWH4



Louver Termination  
TK-KPWL4

Hood Termination  
TK-KPWH4

These terminations are used when venting out through the wall and are compatible with the T-Vent pipe system. These terminations are special stainless steel vents for gas appliances and are UL listed as Category II, III and IV. There are two types of terminations: the Louver termination and the Hood termination. For different wall thicknesses, there are two ranges of lengths available (refer to the venting brochure for details). Install these vent terminations in accordance with their installation instructions and any applicable local codes.

8. Direct-Vent Concentric Termination: TK-KPCT43



Used when terminating direct-vent (sealed-combustion) systems, with direct-vent models that require a 76mm (3 in.) intake and a 102mm (4 in.) exhaust. This concentric termination provides the convenience of only having to make one penetration through a sidewall instead of two separate penetrations for the intake and exhaust piping. The termination includes a bird screen, restricting small animals, pests, and foreign objects from entering into the vent system. This sidewall termination is available in three different sizes, to cover all ranges of wall thicknesses.

Direct-vent Concentric Termination	
Part#	Covering wall thickness
TK-KPCT43-1	99 - 180mm (3.9 – 7.1 in.)
TK-KPCT43-2	175 - 257mm (6.9 – 10.1 in.)
TK-KPCT43-3	249 - 330mm (9.8” – 13.0 in.)

## High-altitude Installations

Check the elevation where your water heater is installed. Set DIPswitches shown in the table below depending on the altitude.

### 110 & 310 Models

Altitude	0 to 2,000 ft (DEFAULT)	2,000 to 4,000 ft	4,000 to 6,000 ft	Over 6,000 ft
Switch No. 3	OFF	ON	OFF	Consult our Technical Services at 1-888-479-8324
Switch No. 4	OFF	OFF	ON	

### 510 Models (Left bank of DIPswitches)

Altitude	0 to 2,000 ft (DEFAULT)	2,000 to 4,000 ft	4,000 to 6,000 ft	Over 6,000 ft
Switch No. 4	OFF	ON	OFF	Consult our Technical Services at 1-888-479-8324
Switch No. 5	OFF	OFF	ON	

- The dark squares indicate the direction the DIPswitches should be set to.

### 110 & 310 Computer board

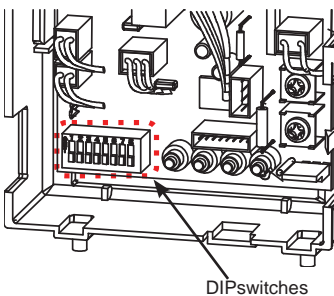

### 510 Computer board

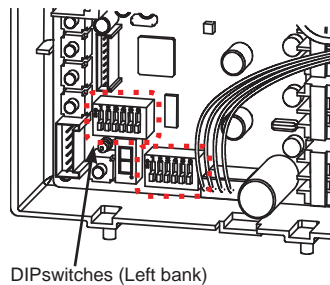



**DO NOT** adjust any DIPswitches on the right bank for the 510 models.

**WARNING**

## Venting Instructions

### General



**DANGER**

- Improper venting of this appliance can result in excessive levels of carbon monoxide which can result in severe personal injury or death.
- Improper installation can cause nausea or asphyxiation, severe injury or death from carbon monoxide and flue gases poisoning. Improper installation will void product warranty.



**CAUTION**

When installing the vent system, all applicable national and local codes must be followed. If you install thimbles, fire stops or other protective devices and they penetrate any combustible or noncombustible construction, be sure to follow all applicable national and local codes.

The water heater must be vented in accordance with the section "Venting of Equipment" of the latest edition of **CSA B149.1 Natural Gas and Propane Installation Code** as well as applicable local building codes.

The manufacturer recommends the "T-Vent" line manufactured by TAKAGI (Refer to "T-Vent" brochure for details). However, the following are also UL listed manufacturers: ProTech Systems Inc. (FasNSeal), Flex-L Inc., Z-Flex Inc. (Z-Vent III), Metal-Fab Inc., and Heat-Fab Inc. (Saf-T Vent).

General rules for venting water heaters are:

- Place the water heater as close as possible to the vent terminator.
- The vent collar of the water heater must be fastened directly to an unobstructed vent pipe.
- Do not weld the vent pipe to the water heater's vent collar.
- Do not cut the vent collar of the unit.
- The vent must be easily removable from the top of the water heater for normal service and inspection of the unit.
- The water heater vent must not be connected to any other gas appliance or vent stack.
- Avoid using an oversized vent pipe or using extremely long runs of the pipe.
- For rooftop venting, a rain cap or other form of termination that prevents rain water from entering into the water heater must be installed.
- Do not common vent or connect any vent from other appliances to the water heater vent.

General rules for vent terminations:

- Avoid locating the water heater vent terminator near any air intake devices. These fans can pick up the exhaust flue products from the water heater and return them to the building. This can create a health hazard.
- Locate the vent terminator so that it cannot be blocked by any debris, at any time. Most codes require that the terminator be at least 305mm (12 in.) above grade, but the installer may determine if it should be higher depending on the job site condition and applicable codes.
- A proper sidewall terminator is recommended when the water heater is vented through a sidewall.
- Regarding the clearances from the exhaust terminator to the air inlet or opening, refer to the next few pages.

## Exhaust venting

(For the 110, 310, & 510 models)

This is a Category III appliance and must be vented accordingly. The vent system must be sealed air tight. All seams and joints without gaskets must be sealed with high heat resistant silicone sealant or UL listed aluminum adhesive tape having a minimum temperature rating of 177°C (350°F). For best results, a vent system should be as short and straight as possible.

- This water heater is a Category III appliance and must be vented accordingly with any 102mm (4 in.) vent approved for use with Category III or Special BH type gas vent.
- Follow the vent pipe manufacturer's instructions when installing the vent pipe.
- Do not common vent this appliance with any other vented appliance (Do not terminate vent into a chimney. If the vent must go through the chimney, the vent must run all the way through the chimney with Category III approved or Special BH vent pipe).
- When the horizontal vent run exceeds 1.5m (5 ft.), support the vent run at 0.9m (3 ft.) intervals with overhead hangers.
- The maximum length of exhaust vent piping must not exceed 15.24m (50 ft.) (deducting 1.5m (5 ft.) for each elbow used in the venting system). Do not use more than 5 elbows.

Diameter	Max. No. of Elbow	Max. Vertical & Horizontal (Total) Vent Length
76mm (3 in.)	5	15.24m (50 ft.)
* For each elbow added, deduct 1.5m (5 ft.) from max. vent length.		
No. of Elbows	Max. Vertical or Horizontal Length	
0	15.24m (50 ft.)	
1	13.7m (45 ft.)	
2	12.2m (40 ft.)	
5	7.6m (25 ft.)	
Excludes elbow termination, rain caps, or the 76mm (3 in.) PVC Concentric Termination		

## Venting Illustrations

(For the 110, 310, & 510 models)

For details of the optional items, refer to the Optional item list.

### Horizontal Installation Diagram:

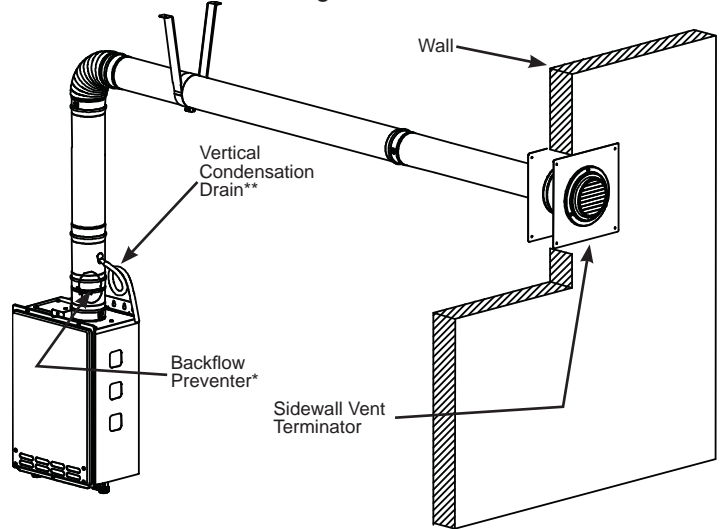

### Vertical Installation Diagram

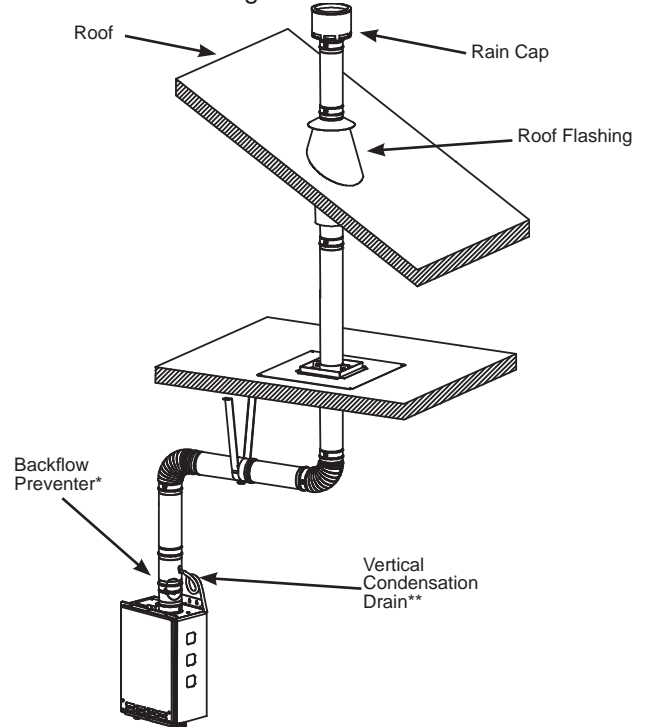

Horizontal Installation Diagram (with direct-venting)

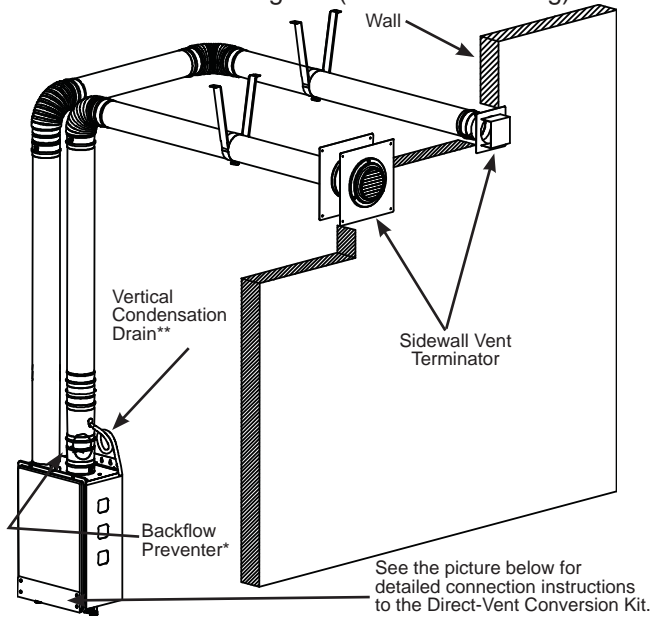

Horizontal Installation Diagram With Direct-Vent Concentric Termination

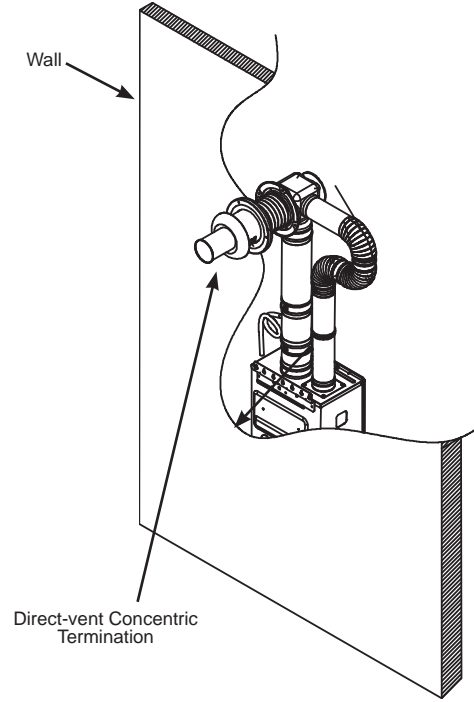

Vertical Installation Diagram (With direct-venting)

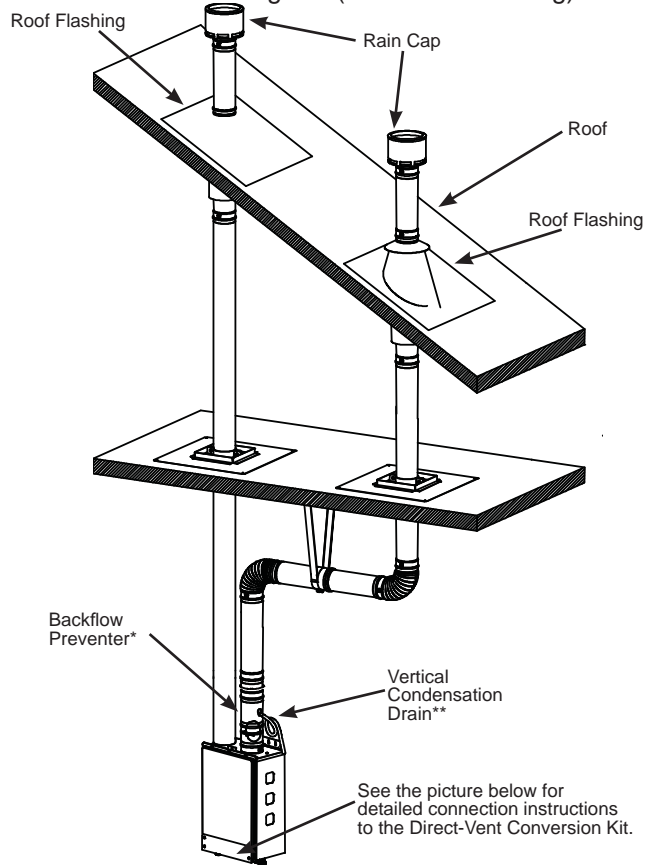

Installation Diagram of Direct-Vent Conversion Kit with water heater

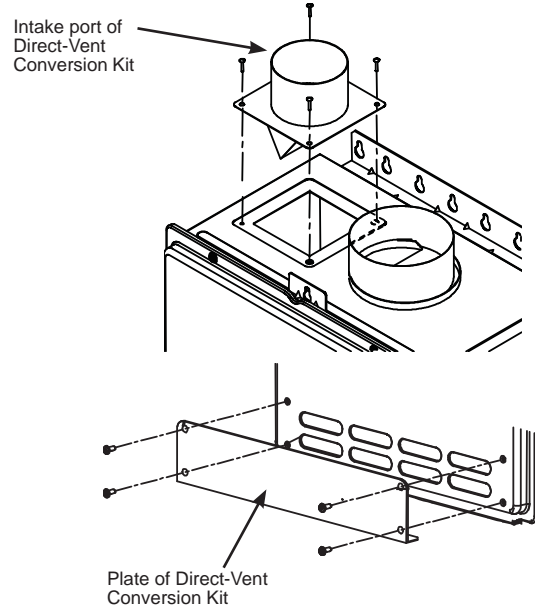

\* Backflow Preventer (Recommended for freezing weather conditions: 2°C (36°F) and below).

\*\* Vertical Condensation Drain must be installed accordance with local codes.

# Vent Termination Clearances

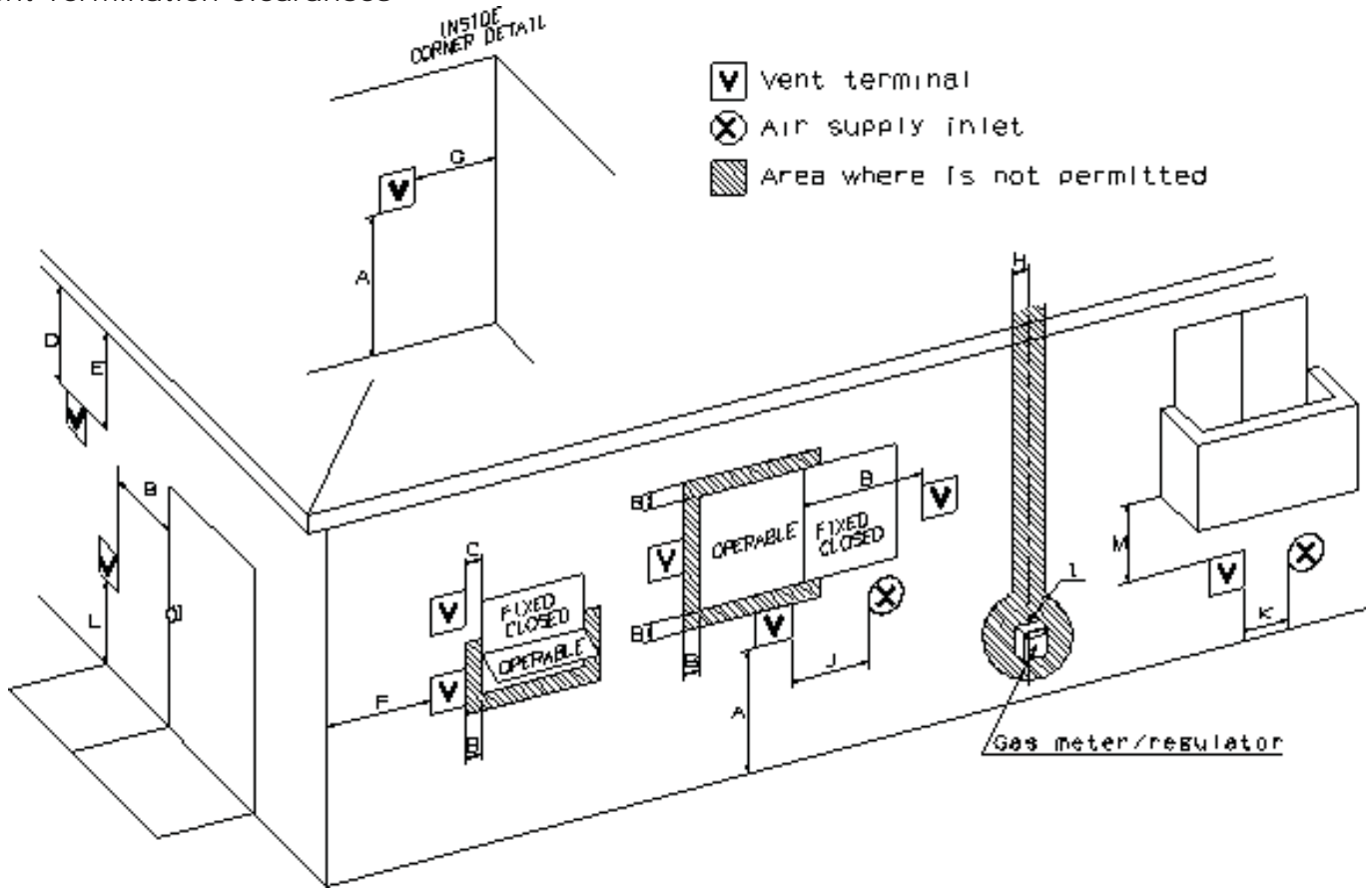

		Canada	U.S.A	
		Direct vent and other than Direct Vent	Direct vent	Other than Direct Vent
A	Clearance above grade, veranda, porch, deck, or balcony.	1 foot	1 foot	1 foot
B	Clearance to window or door that may be opened	3 feet	1 foot	4 feet from below or side opening. 1 foot from above opening.
C	Clearance to permanently closed window	*	*	*
D	Vertical clearance to ventilated soffit located above the vent terminator within a horizontal distance of 2 feet (61cm) from the center line of the terminator.	*	*	*
E	Clearance to unventilated soffit	*	*	*
F	Clearance to outside corner	*	*	*
G	Clearance to inside corner	*	*	*
H	Clearance to each side of center line extended above meter/regulator assembly	3 feet	*	*
I	Clearance to service regulator vent outlet.	3 feet	*	*
J	Clearance to non-mechanical air supply inlet to building or the combustion air inlet to any other application	3 feet	1 foot	4 feet from below or side opening. 1 foot from above opening.
K	Clearance to mechanical air supply inlet.	6 feet	3 feet	3 feet
L	Clearance above paved sidewalk or paved driveway located on public property.	7 feet	*	7 feet
M	Clearance under veranda, porch deck, or balcony.	1 foot	*	*

\* For clearances not specified in **CSA B149.1 Natural Gas and Propane Installation Code**, please use clearances in accordance with local installation codes and the requirement of the gas supplier.



**CAUTION**

Please follow all local and national codes in regards to proper termination clearances. In the absence of such codes, the following clearances can be used as guidelines. Local codes supersede these guidelines.

**For sidewall terminations**

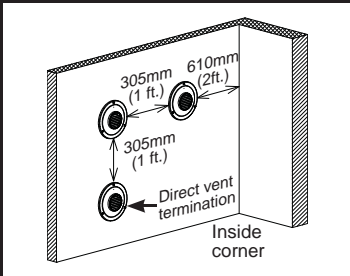
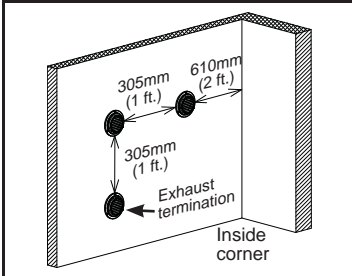

For multiple sidewall exhaust terminations (e.g. multi-unit systems), an exhaust termination must be at least 305mm (1 ft.) away from another exhaust termination. An exhaust termination must also be at least 610mm (2 ft.) away from an inside corner (if the adjacent wall is less than 610mm (2 ft.) of length, the minimum required distance away from the inside corner will be equal to the length of that adjacent wall).

For multiple-unit, direct-vent sidewall terminations that combine the intake and exhaust into a single penetration, space each direct-vent termination at least 305mm (1 ft.) away from each other, no matter the orientation. A direct-vent termination must also be at least 610mm (2 ft.) away from an inside corner (if the adjacent wall is less than 610mm (2 ft.) of length, the minimum required distance away from the inside corner will be equal to the length of that adjacent wall).

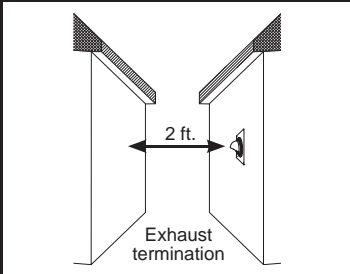
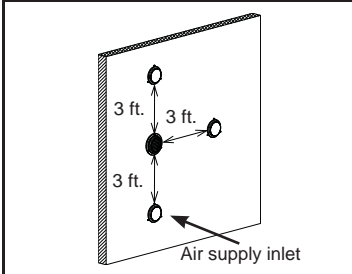

For direct-vent sidewall terminations that use two separate penetrations for the intake and exhaust, distance the intake and exhaust terminations at least 915mm (3 ft.) away from each other, no matter the orientation.

Exhaust and/or direct-vent sidewall terminations should be at least 610mm (2 ft.) away from an opposite surface/wall. Do not place the termination directly in front of an opening into a building.

**For rooftop terminations**

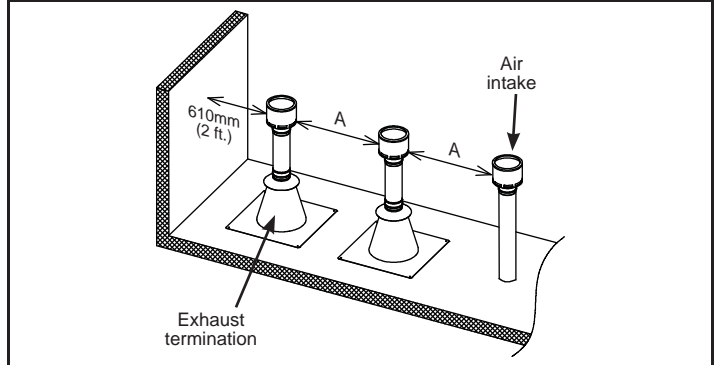
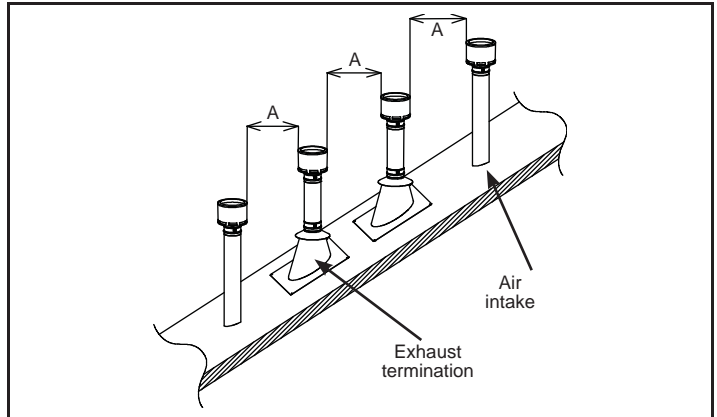

A: In accordance with local codes

For multiple-unit rooftop terminations (whether for standard or direct-vent installations) space all exhaust and intake terminations in accordance with local codes. An exhaust termination must be spaced from a wall or surface in accordance with local codes as well. In the absence of such a code, an exhaust termination must be a horizontal distance of at least 610mm (2 ft.) away from a wall or surface.



# Gas supply and gas pipe sizing

## General



**WARNING**

- Check that the type of gas matches the rating plate first.
- Ensure that any and all gas regulators used are operating properly and providing gas pressures within the specified range shown below. Excess gas inlet pressure may cause serious accidents.
- Conversion of this unit from natural gas to propane or vice versa will void all warranty. Contact your local distributor to get the correct unit for your gas type. **The manufacturer is not liable for any property and/or personal damage resulting from gas conversions.**

- The minimum and maximum inlet gas pressures are:

Gas type	Inlet gas pressure
Natural Gas	Min. 5.0" WC – Max. 10.5" WC
Propane Gas	Min. 8.0" WC – Max. 14.0" WC

- Gas pressure above this specified range for the water heater and/or insufficient gas volume will adversely affect performance. These pressures are measured when the water heater is in full operation.
- Inlet gas pressure must not exceed the above maximum values; gas pressure above the specified range will cause dangerous operating conditions and damage to the unit.
- Until testing of the main gas line supply pressure is completed, ensure the gas line to the water heater is disconnected to avoid any damage to the water heater.

## Gas Connections

1. Install a manual gas shut-off valve between the water heater and the gas supply line.
2. When the gas connections are completed, it is necessary to perform a gas leak test (see below) either by applying soapy water to all gas fittings and observing for bubbles or by using a gas leak detection device.
  - The water heater and its individual shutoff valve must be disconnected from the gas supply piping system during any pressure testing of that system at test pressures in excess of 1/2 psi (3.5 kPa).
  - The water heater must be isolated from the gas supply piping system by closing its individual manual shutoff valve during any pressure testing of the gas supply piping system at test pressures equal to or less than 1/2 psi (3.5kPa).
3. Always purge the gas line of any debris and/or water before connecting to the gas inlet.

**Note:** Size the gas pipe appropriately to supply the necessary volume of gas required for the water heater using **CSA B149.1 Natural Gas and Propane Installation Code** or local codes. Otherwise, flow capabilities and output temperatures may be limited.

## Measuring Inlet Gas Pressure



1. Turn off all electric power to the water heater if service is to be performed.
2. Turn the manual gas valve located on the outside of the unit clockwise 3 to the off position.

The water heater cannot perform properly without sufficient inlet gas pressure. Below are instructions on how to check the inlet gas pressure. **THIS IS ONLY TO BE DONE BY A LICENSED PROFESSIONAL.**

1. Shut off the manual gas valve on the supply gas line.
2. Remove the screw for the pressure port located on the gas inlet of the water heater shown in the diagram below.
3. Connect the manometer to the pressure port.
4. Re-open the manual gas valve. Check to see that there are no gas leaks. Open some of the fixtures that use the highest flow rate to turn on the water heater.
5. Check the inlet gas pressure. When the water heater is on maximum burn, the manometer should read from 5.0" to 10.5" WC for Natural gas, from 8.0" to 14.0" WC for Propane.

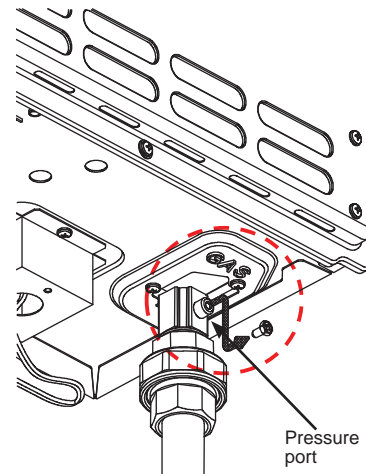

## Water Connections



**CAUTION**

- Do not use this water heater if any part has been submersed under water. Immediately call a licensed professional to inspect the water heater to replace any damaged parts.
- Do not reverse the hot outlet and cold inlet connections to the water heater. This will not properly activate the water heater.

All pipes, pipe fittings, valves and other components, including soldering materials, must be suitable for potable water systems.

1. A manual shut off valve must be installed on the cold water inlet to the water heater between the main water supply line and the water heater.



2. In addition, a manual shut off valve is also recommended on the hot water outlet of the unit. If the water heater is installed within, or subjected to, a closed loop water system, a thermal expansion tank must be installed.
3. Before installing the water heater, flush the water line to remove all debris, and after installation is complete, purge the air from the line. Failure to do so may cause damage to the heater.
4. There is a wire mesh filter within the cold inlet to trap debris from entering your heater. This will need to be cleaned periodically to maintain optimum flow.

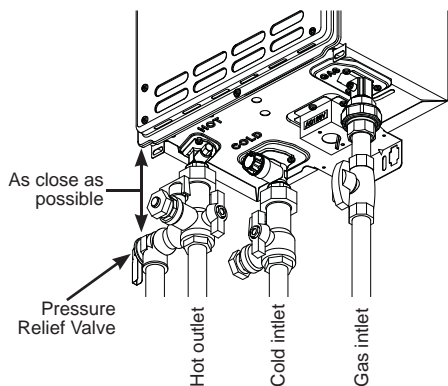

#### Pressure Relief Valve

The water heater has a high-temperature shut off switch built in as a standard safety feature (called a Hi-Limit switch) therefore a “pressure only” relief valve is required.

- This unit does not come with an approved pressure relief valve.
- An approved pressure relief valve must be installed on the hot water outlet.
- The pressure relief valve must conform to **ANSI Z21.22** or **CAN 1-4.4** and installation must follow local code.
- The discharge capacity must be at least 140,000 BTU/h for the 110, 190,000 BTU/h for the 310, and 199,000 BTU/h for the 510.
- The pressure relief valve needs to be rated for a maximum of 150 psi.
- The discharge piping for the pressure relief valve must be directed so that the hot water cannot splash on anyone or on nearby equipment.
- Attach the discharge tube to the pressure relief valve and run the end of the tube to within 150mm (6 in.) from the floor. This discharge tube must allow free and complete drainage without any restrictions.
- If the pressure relief valve installed on the water heater discharges periodically, this may be due to a defective thermal expansion tank or defective pressure relief valve.
- The pressure relief valve must be manually operated periodically to check for correct operation.
- No valve must be placed between the relief valve and the water heater.

## Electrical Connections



**WARNING**

Follow the electrical code requirements of the local authority having jurisdiction. In the absence of such requirements, follow the latest edition of **CSA C22.1 Canadian Electrical Code, Part 1**.



**CAUTION**

When servicing or replacing parts within the water heater, label all wires prior to disconnection to facilitate an easy and error-free re-connection. Wiring errors can cause improper and dangerous operation. Verify proper operation after servicing.

1. The water heater must be electrically grounded. Do not attach the ground wire to either the gas or the water piping.
2. The water heater requires **120 VAC, 60 Hz electrical power supply that is properly grounded.**
  - A proper disconnect (i.e. on/off switch, power plug, etc.) controlling the main power to the water heater must be provided for service reasons. (Must comply with local codes).
  - Connect the power supply to the water heater exactly as shown in the wiring diagram.
3. A green screw is provided in the junction box to ground the connection.
4. Can be hardwired or wired to a plug-in.
5. The use of a surge protector is recommended in order to protect the unit from power surges.

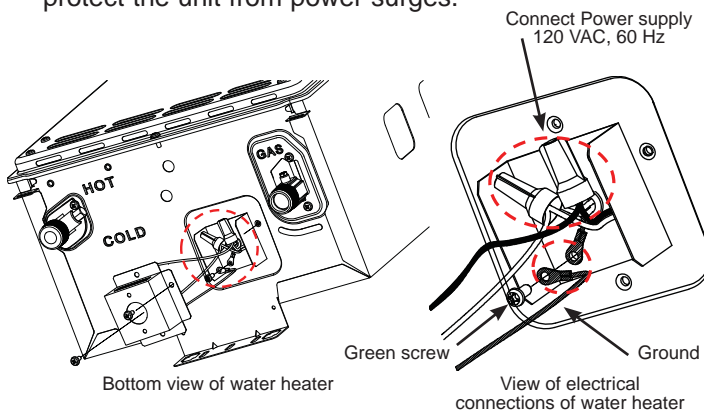

## Remote Controller Connections

To connect the remote controller to the water heater:

1. Disconnect power supply from the water heater.
2. Take off the water heater's front cover.
3. Locate the remote controller terminal, pictured below (located around the lower right-hand side of the computer board).
4. Open the plastic cover of the remote controller, and then attach the two fork terminals to connector base of the backside the remote controller with two screws. Make sure the terminals are firmly fixed.
5. Pull the remote's wires through the hole at the bottom of the water heater's casing.

6. Properly attach the remote's wires to the remote controller terminal on the computer board. (No polarity)
    - \* Do NOT jump or short-circuit the wires or computer will be damaged.
  7. Replace Front Cover securely.
  8. Wires used for the remote controller connection must be:
    - Minimum 18AWG wire (No polarity)
    - Maximum 122m (400 ft.) long
- \* For detailed connection instructions to the remote controller, refer to the instructions that are packaged with the remote controller.

110 & 310 models

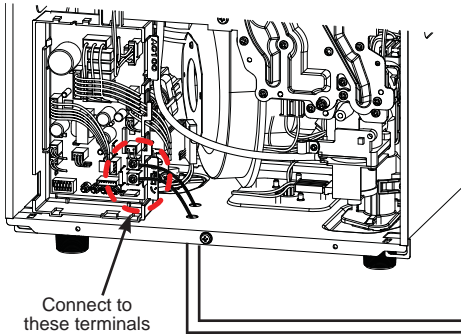

TK-RE02

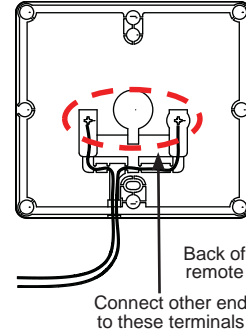
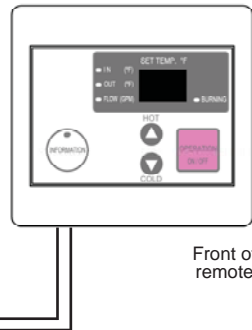

510 models

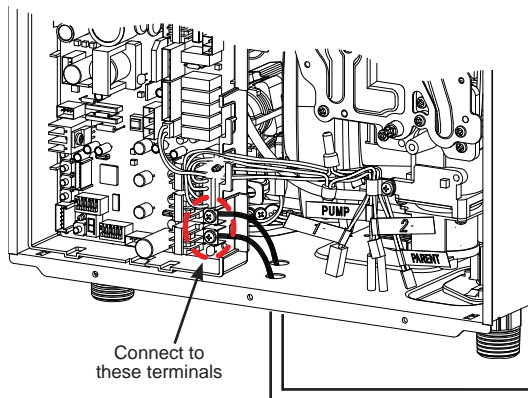

TM-RE30

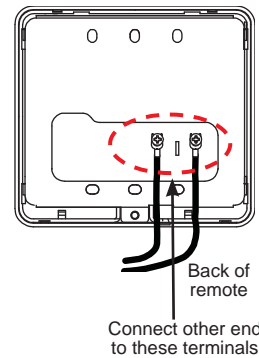
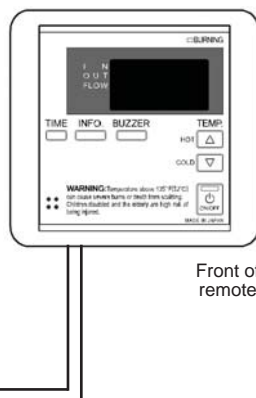

## Pump Control Mode

(Only available on the 510 models)

The 510 water heaters can be used to control a recirculation pump. Proper pump control helps to preserve the life of the system and saves energy as well.

The water heater pump control port is a “normally-open dry contact”, and therefore needs additional components to properly control a recirculation pump. To control a recirculation pump, connect the pump to the “Pump” connector in the water heater as shown in the diagram below. (In an Easy-Link system, connect the pump ONLY to the “PARENT” unit.) The pump is to be connected using suitable relays shown in the diagram below.

Please make sure the relays are properly rated for the recirculation pump.

Using the water heater’s internal thermistors as a temperature control, the recirculation pump will only turn on when recirculation is needed.

- A communication cable (gray color) comes with each 510 model.

You can manifold from 2 to 4 units without the need for a multi-system controller. A 4-unit system has full automatic modulation between 11,000 BTU/h and 796,000 BTU/h.

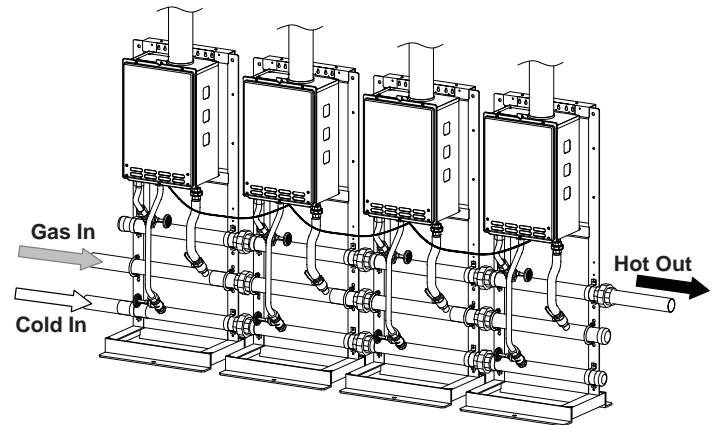

**CAUTION**

In an Easy-Link system, the pump must be connected to the “Pump” connector in the “PARENT” unit only. If the pump is connected to any of the “CHILD” units, the pump will not work.



**CAUTION**

- The Easy-Link system is limited up to **4 units**. If you connect more than 4 units, only the first 4 units will work as a part of the Easy-Link system. The other additional units will not work.
- **All units within an Easy-Link System must be of the same exact model. Different models cannot combine together to form an Easy-Link System.**

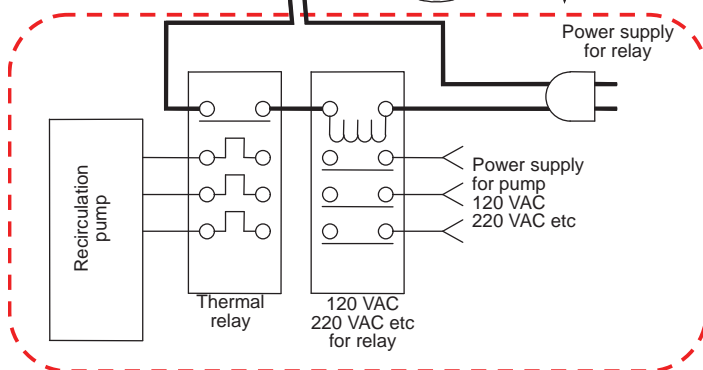
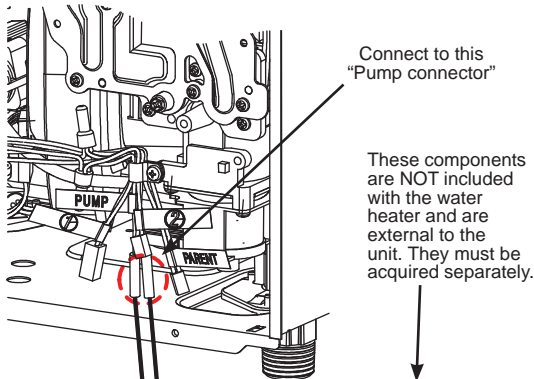

## Easy-link System

(Only available on the 510 models)

### General

The 510 water heaters can be connected with other heaters of the same model with communication cables to work as a multiple-unit manifold system.

- The Easy-Link system allows up to 4 units to manifold together.

### Easy-Link Connection Procedures

1. Verify the set temperatures of all units within the system. Every single water heater must be set to the same set temperature.
2. Select one unit to be the “PARENT” unit.
3. “PARENT” unit:  
Locate the two banks of DIPswitches to the right of the 7-seg. LED on the computer board of the unit that you select to be the “PARENT” unit. Change DIPswitch No. 1 on the right bank of DIPswitches to the ON position. See the computer board diagram as shown in the next page. Do not change any DIPswitches on any of the “CHILD” units.
4. Between the “PARENT” and the “CHILD-1” units:  
Connect the “PARENT” connector of the “PARENT” unit to the “1” connector of the “CHILD-1” unit.
5. Between the “CHILD-1” and the “CHILD-2” units:  
Connect the “2” connector of the “CHILD-1” unit to the “1” connector of the “CHILD-2” unit.
6. Between the “CHILD-2” and the “CHILD-3” units:  
Connect the “2” connector of the “CHILD-2” unit to the “1” connector of the “CHILD-3” unit.
7. Make sure the 7-seg. LED of all the units’ computer boards display the unit #. The numbering system automatically allocates the unit # to each water heater in the Easy-Link system, in accordance with the table below.

Parent unit	Unit #: 1
Child units	Unit #: 2, 3 and 4

(A) 510 Computer board

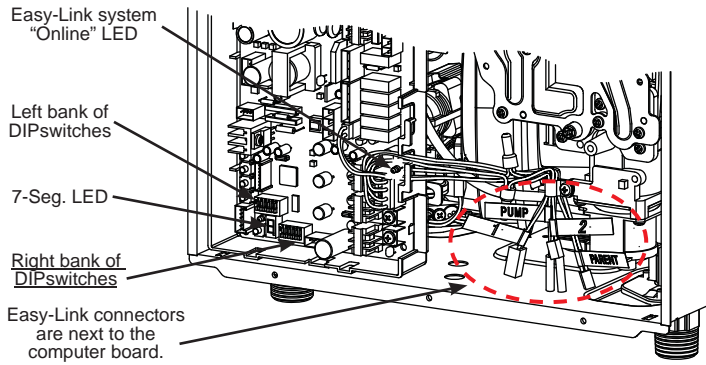

To change the DIPswitch settings for the Easy-Link system, locate the bank of DIPswitches to the right of the 7-seg LED. **Do not adjust the left bank of DIPswitches.**

(B) Basic diagram of connections between the Easy-Link System units.

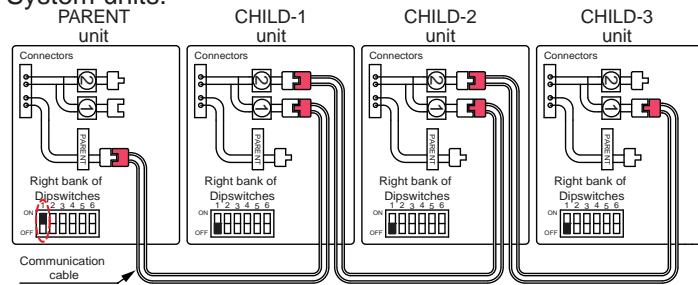

**CAUTION** The dark squares indicate the direction the DIPswitches should be set to.

**Note:**

- A remote controller is not required for the Easy-Link system.
- If running the Easy-Link system without a remote controller, please make sure the temperature settings on ALL the units are set to the same settings. Otherwise, the units will not operate properly.
- If a remote controller is used, the temperature on all the units in the system will automatically be set to the same temperature that is set on the remote.

(C) Examples of incorrect settings and/or connections

CASE 1:

- Unless you change DIPswitch No. 1 of the "PARENT" unit to the "ON" position, the system will not work as an Easy-Link system. The units will operate as individual units.

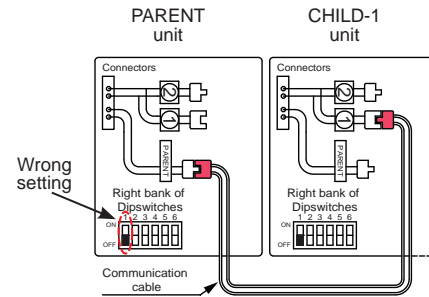

**Wrong DIPswitch setting on the "PARENT" unit**

**Prohibited**

CASE 2:

- If you connect the "1" (or "2") connector of the "PARENT" unit to the "PARENT" (or "1") connector of the "CHILD-1" unit, the system will not work as an Easy-link system. The units will operate as individual units.

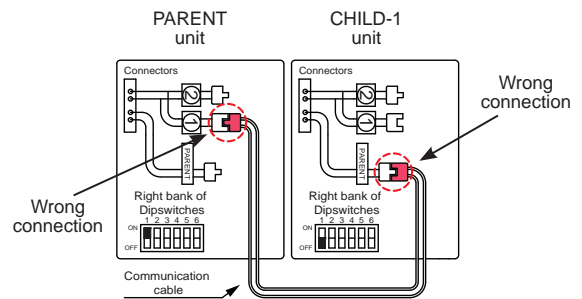

OR

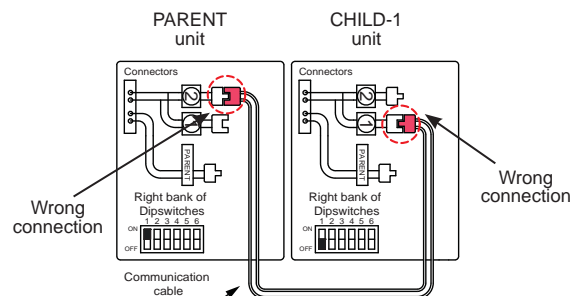



**Wrong connections between the "PARENT" unit and the "CHILD-1" unit**

**Prohibited**

CASE 3:

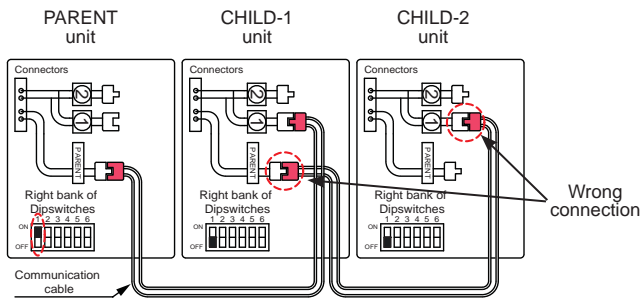
- If you connect the "PARENT" connector of the "CHILD-1" unit to the "1" connector of the "CHILD-2" unit, the "CHILD-2" unit will operate as an individual unit, and will not be part of the Easy-Link system.



 Wrong connections between the "CHILD-1" unit and the "CHILD-2" unit

**Prohibited**

 Connecting two "PARENT" connectors together from two separate units **may damage the computer board**. The communication cable has a female end and a male end so it's impossible to have a PARENT-to-PARENT connection with the communication cable. Do not splice or modify connectors.

**WARNING**

CASE 4:

- If a remote controller (optional) is used, it has to be connected to the "PARENT" unit. If the remote controller is connected to a "CHILD" unit, it will only control that particular individual "CHILD" unit and will not control the Easy-Link system as a whole.

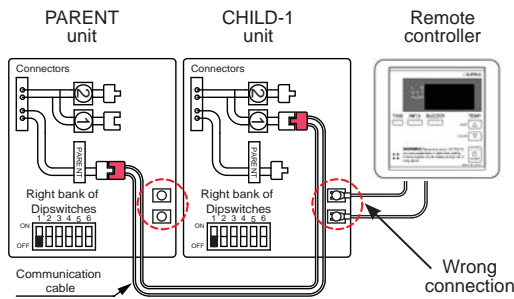

 Remote controller connected to incorrect unit

**Prohibited**

APPLICATIONS

Space-Heating Applications

 **WARNING**

- In order to purge air in water pipes within a closed-loop system, an air vent and air separator should be installed in to the system. Required circulation flow rates are labeled next to each application diagram. These flow rate requirements must be followed.
- Toxic chemicals used in boiler treatments such as alcohol, glycerol and glycol groups must not be introduced into the system if the system incorporates an open-loop potable water system.
- The water heater can be used to supply potable water and space heating and shall not be connected to any heating system or component(s) previously used with non-potable water where any chemicals were added to the water heating appliances.
- When the system requires water for space heating at temperatures higher than required for other uses, a means such as a mixing valve shall be installed to temper the water for those other uses in order to reduce scald hazard potential.
- Water temperature over 52°C (125°F) can cause severe burns instantly or death from scalds.
- Chemicals such as diluted Glycol can be used for radiant floor, Hydro/fan coil air or Baseboard heating only. The diluted solution of glycol must contain between 25 and 55% of Glycol. Be aware that in closed-loop glycol systems, low pressure in the heat exchanger can cause low-temperature boiling, resulting in excessive noise and damage to the water heater. Consult with the glycol maker for specifications prior to use.



## Recirculation

- The recirculation pump is to be controlled by:
  - Dual-set aquastat (recommended w/timer)
  - OR**
  - “Pump Control Mode” (510 Models only). Refer to pg. 20.
- The recirculation pump is to provide no less than 7.5 l/min (2 GPM (US)) and no more than 15 l/min (4 GPM (US)) through each activated unit in the system.

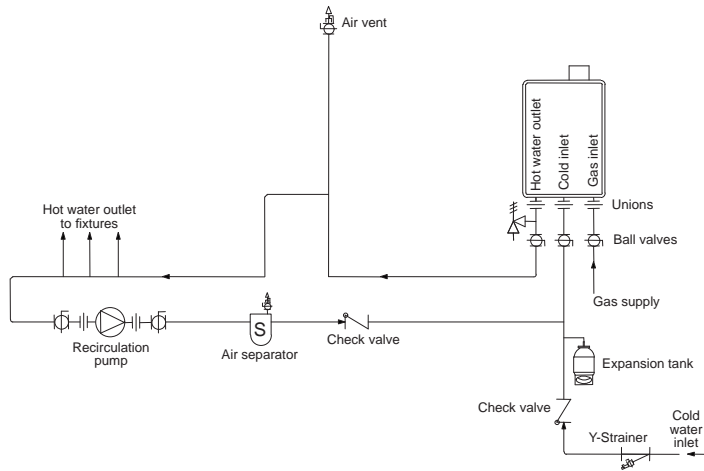

## Dual-purpose Hot Water Heating

(Domestic and Space Heating):

Diagrammatic layout of Radiant Heating and Domestic Water Heater.

- \* The recirculation pump is to provide no less than 7.5 l/min (2 GPM (US)) and no more than 15 l/min (4 GPM (US)) through each activated unit in the system.

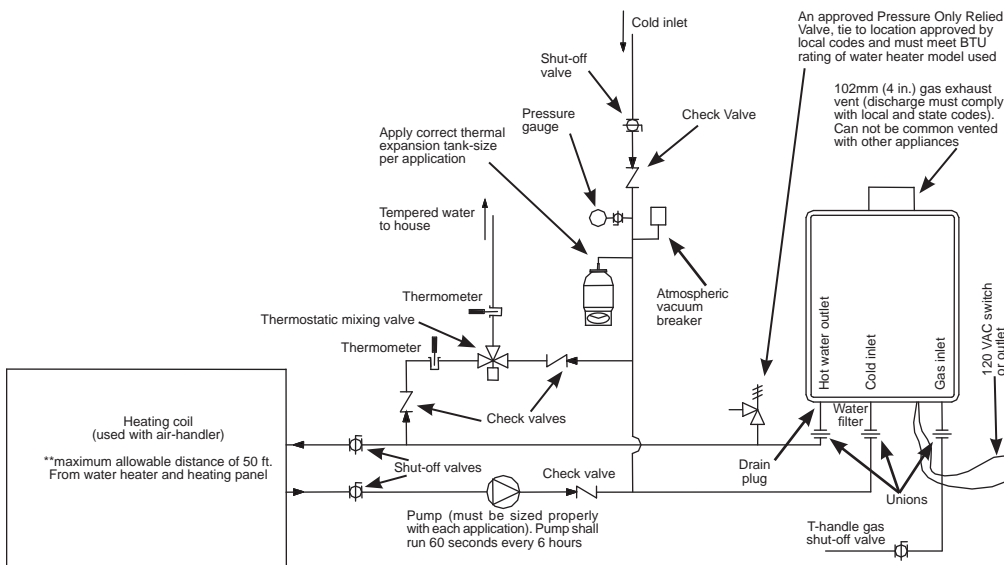

### Note:

- Priority Control Devices** such as a flow switch, an Aquastat or other electronic controller can be used to prioritize the domestic water system over the heating system.
- Follow all local codes.
- This illustration is a concept design only. There are a wide variety of variations to the application of controls and equipment presented. Designers must add all necessary safety and auxiliary equipment to conform to code requirements and design practice. For more details, contact the manufacturer.

## INITIAL OPERATION

### FOR YOUR SAFETY, READ BEFORE OPERATING

- Check the GAS and WATER CONNECTIONS for leaks before firing unit for the first time.
- Open the main gas supply valve to the unit using only your hand to avoid any spark. Never use tools. If the knob will not turn by hand, do not try to force it; call a qualified service technician. Forced repair may result in a fire or explosion due to gas leaks.
- Be sure to check for the presence of leaking gas toward the bottom of the unit because some gases are heavier than air and may settle towards the floor.
- Check the GAS PRESSURE. Refer to pg. 17.
- Do not try to light the burner manually. It is equipped with an electronic ignition device which automatically lights the burner.
- Check for PROPER VENTING and COMBUSTIBLE AIR to the water heater.
- Purge the GAS and WATER LINES to remove any air pockets.
- Do not use this water heater if any part has been submersed under water. Immediately call a qualified service technician to inspect the water heater and to replace any damaged parts.



**WARNING**

#### IF YOU SMELL GAS:

- Do not try to start the water heater.
- Do not touch any electric switches; do not use any phone in your building.
- Immediately call your gas supplier from a neighbor's phone. Follow the gas supplier's instructions.
- If you cannot reach your gas supplier, call the fire department.

1. Once the above checks have been completed, please clean filter of any debris. Refer to pg. 29 for instructions.



2. Fully open the manual water control valve on the water supply line.



3. Open a hot water tap to verify that water is flowing to that tap. Then close the hot water tap.



4. Fully open the manual gas control valve installed.



5. Turn on the 120 VAC, 60 Hz power supply to the water heater.

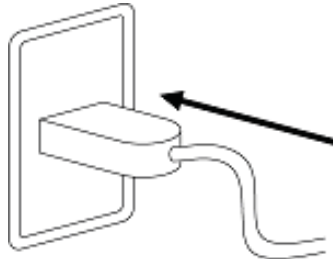

6. Now you are ready to enjoy hours of endless hot water.





## FOR YOUR SAFETY READ BEFORE OPERATING

**WARNING:** If you do not follow these instructions exactly, a fire or explosion may result causing property damage, personal injury or loss of life.

- A. This water heater does not have a pilot. It is equipped with an ignition device that automatically lights the burner. Do not try to light the burner by hand.
- B. BEFORE OPERATING smell all around the water heater area for evidence of leaking gas. Be sure to smell next to the floor because some gas is heavier than air and will settle on the floor.  
WHAT TO DO IF YOU SMELL GAS.
  - Do not try to light any appliance.
  - Do not touch any electric switch, do not use any phone in your building.
  - Immediately call your gas supplier from a neighbor's phone. Follow the gas supplier's instructions.
  - If you cannot reach your gas supplier, call the fire department.
- C. Use only your hand to turn the gas valve knob. Never use tools. If the knob will not turn by hand, don't try to repair it. Call a qualified service technician. Forced or attempted repair may result in a fire or explosion.
- D. Do not use this water heater if any part has been under water. Immediately call a qualified service technician to inspect the water heater and to replace any damaged parts.

## OPERATING INSTRUCTIONS

1. **STOP!** Read the safety information above or in the Owners Manual.
2. Turn off all electric power to the water heater.
3. Do not attempt to light the burner by hand.
4. Turn the manual gas valve located on the outside of the unit clockwise to the off position.
5. Wait five (5) minutes to clear out any gas. If you then smell gas. STOP! Follow "B" in the safety information above on this label. If you don't smell gas, go to next step.
6. Turn the manual gas valve located on the outside of the unit counter clockwise to the ON position.
7. Turn on all electrical power to the water heater.
8. If the water heater will not operate, follow the instructions "to Turn Off Gas to water heater" and Call your service technician or gas supplier.

## TO TURN OFF GAS TO APPLIANCE

1. Turn off all electric power to the water heater if service is to be performed.
2. Turn the manual gas valve located on the outside of the unit clockwise to the off position.

## DANGER



Vapors from flammable liquids will explode and catch fire causing death or severe burns.

Do not use or store flammable products such as gasoline, solvents or adhesives in the same room or area near the water heater.

Keep flammable products:

1. Far away from heater
2. In approved containers
3. Tightly closed
4. Out of children's reach

Vapors:

1. Cannot be seen
2. Vapors are heavier than air
3. Go a long way on the floor
4. Can be carried from other rooms to the main burner by air currents

**WARNING:** Do not install water heater where flammable products will be stored.

Read and follow water heater warnings and instructions. If owner's manual is missing, contact the manufacturer.

## WARNING

The outlet hot water temperature of the water heater is factory set at 50°C (122°F).

Use this heater at your own risk. The set outlet water temperature can cause severe burns instantly or death from scalds. Test the water before bathing or showering.

Do not leave children or an infirm person in the bath unsupervised.

## DANGER



Hot Water Heater temperature over 52°C (125°F) can cause severe burns instantly or death from scalding. Children, disabled and elderly are at the highest risk of being scalded. Feel water temperature before bathing or showering. Temperature limiting valves are available. Ask a professional person.

# NORMAL OPERATION

## General





- Hot Water temperatures over 52°C (125°F) can cause severe burns instantly or death from scalding.
- The outlet hot water temperature of the water heater is factory set at 50°C (122°F).
- Feel the water temperature before bathing or showering.



### Note:

- Flow rate to activate the water heater: 2.8 l/min (0.75 gallon (US) per minute).
- Flow rate to keep the water heater running: 1.5 l/min (0.4 gallon (US) per minute).

<p>1. Open a hot water tap.*</p> 	<p>2. Mix cold water with the hot to get the correct temperature water.</p> 	<p>3. Close the hot water tap.</p> 
--	---	--

\* If a remote controller installed, turn the remote controller ON by pressing the power ON/OFF button on the remote controller and then set the temperature by pressing the HOT/COLD buttons before opening a hot water tap. The temperature is displayed when the remote controller is turned ON.

## Temperature Settings

### Without Remote Controller

Depending on the model, there are 4 or 8 temperatures that you can select from by changing the DIPswitch settings on the computer board without the remote controller. See the table below.

Model	Temperatures available			
110	45°C (113°F)	50°C (122°F)	55°C (131°F)	60°C (140°F)
310	45°C (113°F)	50°C (122°F)	55°C (131°F)	60°C (140°F)
510	40°C (104°F)	45°C (113°F)	50°C (122°F)	55°C (131°F)
	60°C (140°F)	70°C (158°F)	80°C (176°F)	85°C (185°F)

For detailed DIPswitch settings for each temperature, refer to the following chart.

- The temperature has been preset at the factory to 50°C (122°F).
- If temperatures other than the ones listed above are required, the remote controller can provide several more temperature options. Refer to pg. 8 for a list of available temperatures on the remote controller.
- This water heater is an on-demand, tankless water heater designed to efficiently supply endless hot water without reference to temperature settings.

## DIPswitch Settings For Temperature

### 110 & 310 Computer board

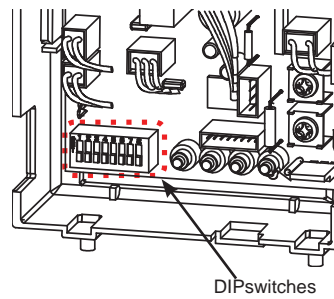

### 510 Computer board

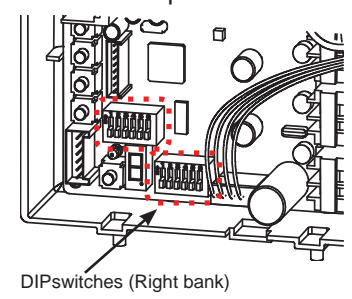

### 110 & 310 Models

Temperature Settings				
	45°C (113°F)	50°C (122°F) DEFAULT	55°C (131°F)	60°C (140°F)
Switch No. 7	OFF	ON	OFF	ON
Switch No. 8	OFF	OFF	ON	ON

### 510 Models

Temperature Settings (Right bank)				
	40°C (104°F)	45°C (113°F)	50°C (122°F) DEFAULT	55°C (131°F)
Switch No. 4	OFF	OFF	OFF	ON
Switch No. 5	OFF	ON	OFF	OFF
Switch No. 6	ON	OFF	OFF	OFF
	60°C (140°F)	70°C (158°F)	80°C (176°F)	85°C (185°F)
Switch No. 4	OFF	ON	ON	ON
Switch No. 5	ON	OFF	ON	ON
Switch No. 6	ON	ON	OFF	ON



**WARNING**

- **DO NOT set to 85°C (185°F) if you use your water heater in a recirculation system. This will cause damage to the heater and void the warranty. (This temperature setting is only available on the 510 models).**
- DO NOT adjust the left bank of DIPswitches. (For the 510 models).
- Turn off the power supply to the water heater before changing the DIPswitch settings.
- Only change the switches with the dark squares. The dark squares indicate which direction the DIPswitch should be set to.

Model	Unit of Measure	Natural Gas	Propane
110	l/hr	681	681
	l/min	11.35	11.35
	GPH (US)	180	180
	GPM (US)	3	3
310	l/hr	931	931
	l/min	15.5	15.5
	GPH (US)	246	246
	GPM (US)	4.1	4.1
510	l/hr	954	954
	l/min	15.9	15.9
	GPH (US)	252	252
	GPM (US)	4.2	4.2

**Flow**

- The flow rate through the water heater is limited to a maximum of 25 l/min (6.6 GPM (US)) for the 110, 30.3 l/min (8.0 GPM (US)) for the 310, and 37.8 l/min (10.0 GPM (US)) for the 510.
- The temperature setting, along with the supply temperature of the water will determine the flow rate output of the unit.
- Please refer to the temperature vs. gallons per minute charts on pg. 43 to determine the likely flow rates based on your local ground water temperature and your desired outlet water temperature.

Household Flow Rates		
Appliance/Use	Flow Rate	
	l/min	GPM (US)
Lavatory Faucet	3.78	1.0
Bath Tub	15.2 - 37.8	4.0 – 10.0
Shower	7.5	2.0
Kitchen Sink	5.6	1.5
Dishwasher	5.6	1.5
Washing machine	15.2	4.0
Taken from UPC 2006		

- Based on the **CAN/CSA P.7** test method for measuring energy loss of gas-fired instantaneous water heaters, the water heater is rated for litres per hour (l/hr) ((US) gallons per hour (GPH)) or litres per minute (l/min) ((US) gallons per minute (GPM)) for Natural Gas and Propane, when raising the water temperature by 43C° (77F°) (from 14°C to 57°C (58°F to 135°F)). See the following chart.

- Refer to the table on the left for typical household plumbing fixture flow rates to determine what the water heater can do in a household application.

**Freeze protection system**

- This unit comes equipped with heating blocks to protect it against damages associated with freezing.
- For this freeze protection system to operate there has to be electrical power to the unit. Damage to the heat exchanger caused by freezing temperatures due to power loss is not covered under the warranty. In cases where power losses can occur, consider the use of a backup power supply.
- The freeze protection system will activate when the surrounding and/or outside temperatures drop below 2.5°C (36.5°F).
- For the 110, 310, & 510:
  - In any areas subject to freezing temperatures, freezing issues can only occur if cold air enters through the venting into the heat exchanger, whether by negative pressures within the installation location or by strong outside winds.
  - The manufacturer also highly recommends the use of a backflow vent damper to minimize the amount of cold air entering through the exhaust venting when the water heater is off.
- It is the installer’s responsibility to be aware of freezing issues and take all preventative measures. The manufacturer will not be responsible for any damage to the heat exchanger as a result of freezing.
- If you will not be using your heater for a long period of time:
  1. Completely drain the unit of water. Refer to pg. 29.
  2. Disconnect power to your heater.
 This will keep your unit from freezing and being damaged.



**CAUTION**

Only pipes within the water heater are protected by the freeze protection system. Any water pipes (hot or cold) located outside the unit will not be protected. Properly protect and insulate these pipes from freezing.

### Maintenance and service



**WARNING**

Turn off the electrical power supply and close the manual gas shutoff valve **WARNING** and the manual water control valve before servicing.

- Clean the cold-water inlet filter. (Refer to diagram on the right.)
- Be sure that all openings for combustion and ventilation air are not blocked.
- The venting system should be checked annually for any leaks, corrosion, blockages or damage.
- The burner should be checked annually for dust, lint, grease or dirt.
- Keep the area around the water heater clear. Remove any combustible materials, gasoline or any flammable vapors and liquids.
- In accordance with all local codes and common safety practices, water discharged from the pressure relief valve can cause severe burns instantly from scalding. **DO NOT** touch the pressure relief valve.
- If the relief valve discharges periodically, it may be due to thermal expansion in a closed water supply system. Contact the water supplier or local plumbing inspector on how to correct this situation.
- Visual check of burner flames (see below) through the burner window in the burner assembly located at the middle of the water heater.

### Unit Draining and Filter Cleaning

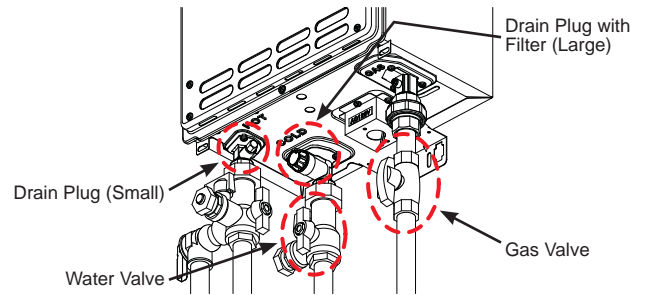

1. Close the manual gas shut off valve.
2. Turn off power to the unit and wait a couple of seconds. Turn on again.
3. Wait 30 seconds, and then turn off power to the unit, yet again.
4. Close the water shut off valve.
5. Open all hot water taps in the house. When the residual water flow has ceased, close all hot water taps.
6. Have a bucket or pan to catch the water from the unit's drain plugs. Unscrew the two drain plugs (Large and small) to drain all the water out of the unit.
7. Wait a few minutes to ensure all water has completely drained from unit.
8. Clean the filter: Check the water filter located within the cold inlet. With a tiny brush, clean the water filter of any debris which may have accumulated and reinsert the filter back into the cold water inlet.
9. Securely screw the drain plugs back into place. Hand-tighten only.

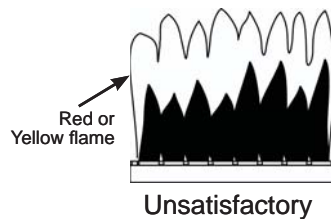
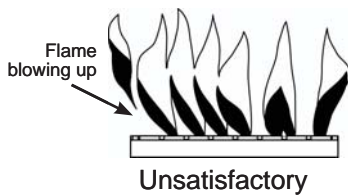
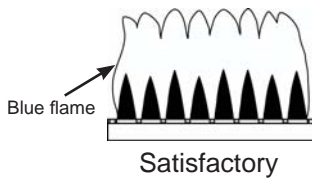

The manufacturer recommends having the unit checked once a year or as necessary by a licensed technician. If repairs are needed, any repairs should be done by a licensed technician.

# TROUBLESHOOTING

## General

	PROBLEM	SOLUTIONS
TEMPERATURE and AMOUNT OF HOT WATER	It takes long time to get hot water at the fixtures.	<ul style="list-style-type: none"> <li>The time it takes to deliver hot water from the water heater to your fixtures depends on the length of piping between the two. The longer the distance or the bigger the pipes, the longer it will take to get hot water.</li> <li>If you would like to receive hot water to your fixtures quicker, you may want to consider a hot water recirculation system. (pg. 23)</li> </ul>
	The water is not hot enough.	<ul style="list-style-type: none"> <li>Compare the flow and temperature. See the charts on pg. 43.</li> <li>Check cross plumbing between cold water lines and hot water lines.</li> <li>Is the gas supply valve fully open? (pg. 27)</li> <li>Is the gas line sized properly? (pg. 16)</li> <li>Is the gas supply pressure enough? (pg. 17)</li> <li>Is the set temperature set too low? (pg. 27)</li> </ul>
	The water is too hot.	<ul style="list-style-type: none"> <li>Is the set temperature set too high? (pg. 27)</li> </ul>
	The hot water is not available when a fixture is opened.	<ul style="list-style-type: none"> <li>Make sure the unit has 120 VAC, 60 Hz power supply.</li> <li>If you are using the remote controller, is the power button turned on?</li> <li>Is the gas supply valve fully open? (pg. 24)</li> <li>Is the water supply valve fully open? (pg. 24)</li> <li>Is the filter on cold water inlet clean? (pg. 29)</li> <li>Is the hot water fixture sufficiently open to draw at least 2.8 l/min (0.75 GPM (US)) through the water heater? (pg. 27)</li> <li>Is the unit frozen?</li> <li>Is there enough gas in the tank/cylinder? (For Propane models)</li> </ul>
	The hot water turns cold and stays cold.	<ul style="list-style-type: none"> <li>Is the flow rate enough to keep the water heater running? (pg. 27)</li> <li>If there is a recirculation system installed, does the recirculation line have enough check valves? (pg. 23)</li> <li>Is the gas supply valve fully open? (pg. 24)</li> <li>Is the filter on cold water inlet clean? (pg. 29)</li> <li>Are the fixtures clean of debris and obstructions?</li> <li>Check if the flow rate is too low. (pg. 27)</li> </ul>
	Fluctuation in hot water temperature.	<ul style="list-style-type: none"> <li>Is the filter on cold water inlet clean? (pg. 29)</li> <li>Is the gas line sized properly? (pg. 16)</li> <li>Is the supply gas pressure sufficient? (pg. 17)</li> <li>Check for cross connection between cold water lines and hot water lines.</li> </ul>
WATER HEATER	Unit does not ignite when water goes through the unit.	<ul style="list-style-type: none"> <li>Is the flow rate over 2.8 l/min (0.75 GPM (US))? (pg. 27)</li> <li>Check for the filter on cold water inlet. (pg. 29)</li> <li>Check for reverse connection and cross connection.</li> <li>If you use the remote controller, is the power button turned on?</li> <li>Check if the inlet temperature is too high.</li> </ul>
	The fan motor is still spinning after operation has stopped.	<ul style="list-style-type: none"> <li>This is normal. After operation has stopped, the fan motor keeps running from 15 to 70 seconds in order to re-ignite quickly, as well as purge all the exhaust gas out of the flue.</li> </ul>
	Unit sounds abnormal while in operation	<ul style="list-style-type: none"> <li>Contact the manufacturer at 1-888-479-8324.</li> </ul>

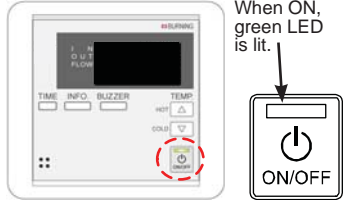
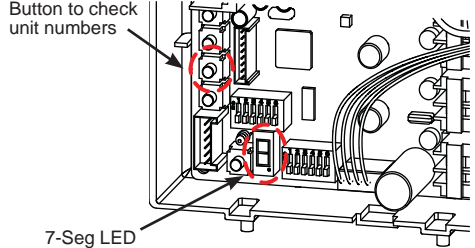

	PROBLEM	SOLUTIONS
Remote controller: TM-RE30/TK-RE02 (OPTIONAL)	Remote controller does not display anything when the power button is turned on.	<ul style="list-style-type: none"> <li>• Make sure the unit is supplied with power.</li> <li>• Make sure the connection to the unit is correct. (pg. 19)</li> </ul>
	An ERROR code is displayed.	<div style="display: flex; align-items: flex-start;"> <div style="flex: 1;"> <p>TM-RE30 only:</p> <p>If the green LED lights up, the remote controller has been turned ON. When the unit has not operated for five minutes or more, the display turns off to conserve energy.</p> </div> <div style="flex: 1; text-align: right;">  </div> </div>
EASY-LINK SYSTEM	How are the unit numbers assigned?	<ul style="list-style-type: none"> <li>• For an Easy-Link system, the Parent unit is always labeled #1 and all other subsequent Child units are numbered randomly.</li> <li>• To check which numbers are assigned to which Child units, push the button on the computer board of any Child unit as shown below. The unit number will be displayed on the 7-Seg LED. (Refer to pg. 20-22)</li> </ul> <div style="text-align: right;">  </div>



## Error Codes

- The units are self diagnostic for safety and convenience when trouble shooting.
- If there is a problem with the installation or the unit, depending on the model or if there is a remote controller installed, it will either display a numerical error code on the 7-Seg LED on the computer board (Only for the 510 models), display a blinking red LED (for the 110 & 310 models), or the error code will display on the remote controller if it is installed.
- Consult with the table on the following page for the cause of each error code.

### 110 & 310

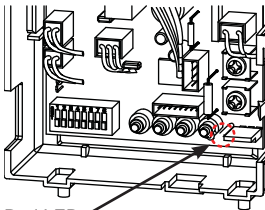

Red LED  
Error code on the computer board



Error code on the TK-RE02

### 510

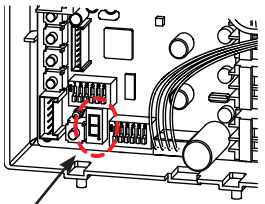

7-Seg LED  
Error code on the computer board



Error Code the TM-RE30

## Easy-Link System

(For the 510 models only)

Error codes will display differently with units installed within an Easy-Link System, not only to show what the error code is, but to also indicate which unit within the system has the error code. Below is a sample of how the same error code is displayed in an Easy-Link System.

Example: If Unit #2 has the "321" error code (inlet thermistor failure)

- Parent unit: It will display "3"... "2"... "1"... "0"... "2" one digit at a time on the 7-Seg LED. The first 3 numbers indicate the error code. The last two numbers indicate that Unit #2 has the error code.
- Unit #2: It will display "3"... "2"... "1" on the 7-Seg LED, just like in the Single Unit example.
- Unit #3 & #4: These units will not display anything, as the error code does not pertain to them.
- TM-RE30: It will display "232" on its screen. The first "2" indicates that Unit #2 has the error. The "32" indicates the first two digits of the "321" error code.

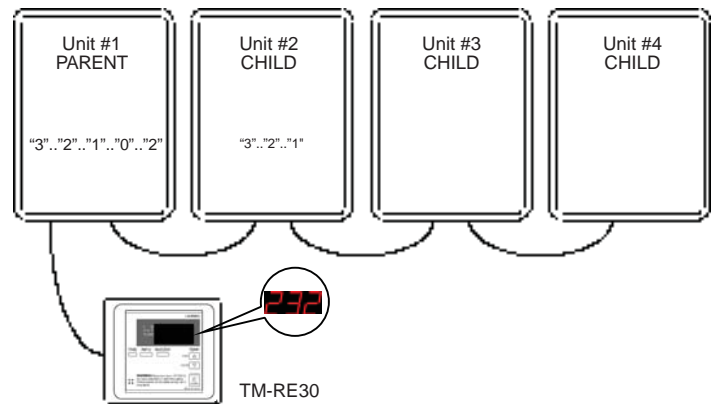

## Single Unit Installations

Example: If your unit displays the "321" error code (which signifies an inlet thermistor failure)

- 110 & 310 models: The red LED on the computer board will be blinking two times.
- If the TK-RE02 is installed: "32" will display on the screen in its entirety.
- 510 models: The 7-seg. LED on the computer board will display "3"... "2"... "1" in that order one digit at a time and continually repeat.
- If the TM-RE30 is installed: "321" will display on the screen in its entirety.

## Fault Analysis Of Error Codes

If the error code is displayed on the computer board of the water heater or remote controller, please check the following. After checking, **consult with the manufacturer.**

110 & 310		510	Malfunction description	Diagnosis
Red LED	TK-RE02	TM-RE30		
One Time	03	031	Incorrect DIPswitch setting	<ul style="list-style-type: none"> <li>Check the DIPswitch settings on the PCB. (Part #701)</li> </ul>
Five Times	10	101	Warning for the "991" error code	<ul style="list-style-type: none"> <li>Check the gas type of the water heater.</li> <li>Check if there is any blockage in the intake air and/or exhaust.</li> <li>If the water heater is installed as a direct-vent system, check whether there is enough distance between the intake air terminal and the exhaust terminal.</li> <li>Check the altitude/elevation of area of where the water heater installed.</li> <li>Check if there is grease and/or dirt in the burner (Part #101) and the fan motor (Part #103), especially if the water heater has been installed in a contaminated area.</li> </ul>
Three Times	11	111	Ignition failure	<ul style="list-style-type: none"> <li>Check if the Hi-limit switch (Part #412) is properly functioning.</li> <li>Check for connection/breakage of wires (Part #413, 708, 709, 710, 712), burn marks on the computer board (Part #701), and/or soot on the flame rod (Part #108).</li> <li>Check if there is a buzzing spark ignition sound coming from the burner (Part #101) when water heater prepares for combustion.</li> <li>Listen for the double "clunk" sound coming from gas valve assembly (Part #102) when water heater goes into combustion.</li> <li>Check if there is leaking from heat exchanger. (Part #401)</li> </ul>
Three Times	12	121	Loss of flame	<ul style="list-style-type: none"> <li>Check if the Hi-limit switch (Part #412) is properly functioning.</li> <li>Check for connection/breakage of wires (Part #413, 708, 709, 710, 712), burn marks on the computer board (Part #701), and/or soot on the flame rod (Part #108).</li> <li>Check if there is leaking from heat exchanger. (Part #401)</li> </ul>
Two Times	31 32	311 321	Output thermistor failure Inlet thermistor failure	<ul style="list-style-type: none"> <li>Check for connection/breakage of wires and/or debris on thermistor. (Part #407, 408, 411, 716)</li> </ul>
N/A	N/A	331	Mixing thermistor failure	
Two Times	39	391	Air-fuel Ratio Rod failure	<ul style="list-style-type: none"> <li>Check for connection/breakage of wires (Part #709) and/or soot on the AFR rod. (Part #108)</li> </ul>

110 & 310		510	Malfunction description	Diagnosis
Red LED	TK-RE02	TM-RE30		
N/A	N/A	441	Flow Sensor Failure (Easy-Link System only)	<ul style="list-style-type: none"> <li>Check for connection/breakage of wires and/or debris on the flow sensor impeller. (Part #402, 717)</li> </ul>
Six Times	51	510	Abnormal Gas Solenoid Valve	<ul style="list-style-type: none"> <li>Check for connection/breakage of wires (Part #708) and/or burn marks on the computer board (Part #701).</li> </ul>
	55	N/A	Abnormal Main Gas Valve	<ul style="list-style-type: none"> <li>Check for connection/breakage of wires (Part #708) and/or burn marks on the computer board (Part #701).</li> </ul>
Four Times	61	611	Fan Motor Fault	<ul style="list-style-type: none"> <li>Check for connection/breakage of wires, dust buildup in the fan motor (Part #103) and/or burn marks on the computer board (Part #701).</li> <li>Check for frozen/corrosion of connectors (Part #103).</li> </ul>
N/A	N/A	651	Flow Adjustment Valve Fault (Easy-Link System only)	<ul style="list-style-type: none"> <li>Inspect the flow adjustment valve (Part #402), for connection/breakage of wires (Part #718), locked motor drive due to scale buildup, and/or water leakage.</li> </ul>
One Time	70	701	Computer board Fault	<ul style="list-style-type: none"> <li>Check for connection/breakage of wires (Part #714) and/or burn marks on the computer board (Part #701).</li> <li>Check the power supply of the water heater.</li> </ul>
Six Times	72	721	False Flame Detection	<ul style="list-style-type: none"> <li>Check if condensate drain is installed on the vent collar of the water heater.</li> <li>Check if there is leaking from heat exchanger (Part #401).</li> </ul>
N/A	74	741	Miscommunication between water heater and remote Controller	<ul style="list-style-type: none"> <li>Check the model type of the remote controller.</li> <li>Inspect the connections between the water heater and remote controller.</li> <li>Check the power supply of the water heater.</li> </ul>
N/A	N/A	761	Miscommunication in Easy-Link system	<ul style="list-style-type: none"> <li>Check if the connections between the parent unit and the child units are correct. Refer to pg. 20-22.</li> </ul>

110 & 310		510	Malfunction description	Diagnosis
Red LED	TK-RE02	TM-RE30		
Five Times	99	991	Imperfect combustion	<ul style="list-style-type: none"> <li>• Check the gas type of the water heater.</li> <li>• Inspect the environment around the water heater. Determine how long the unit has been installed.</li> <li>• Check the altitude/elevation of the area of where the water heater installed.</li> <li>• Check if there is any blockage in the intake air and/or exhaust.</li> <li>• If the water heater is installed as a direct-vent system, check whether there is enough distance between the intake air terminal and the exhaust terminal.</li> <li>• Check if there is grease and/or dirt in the burner (Part #101) and the fan motor (Part #104), especially if the water heater has been installed in a contaminated area.</li> </ul>

# COMPONENTS DIAGRAM

## Case Assembly

110

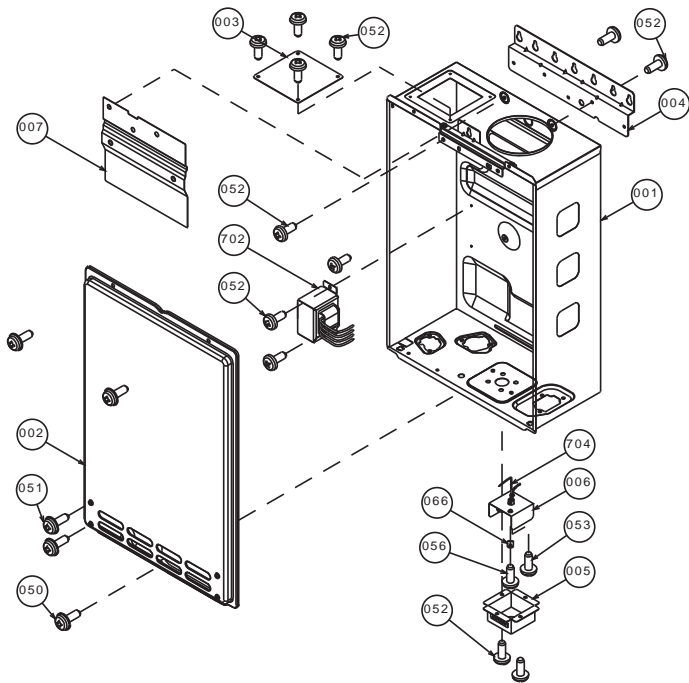

310 & 510

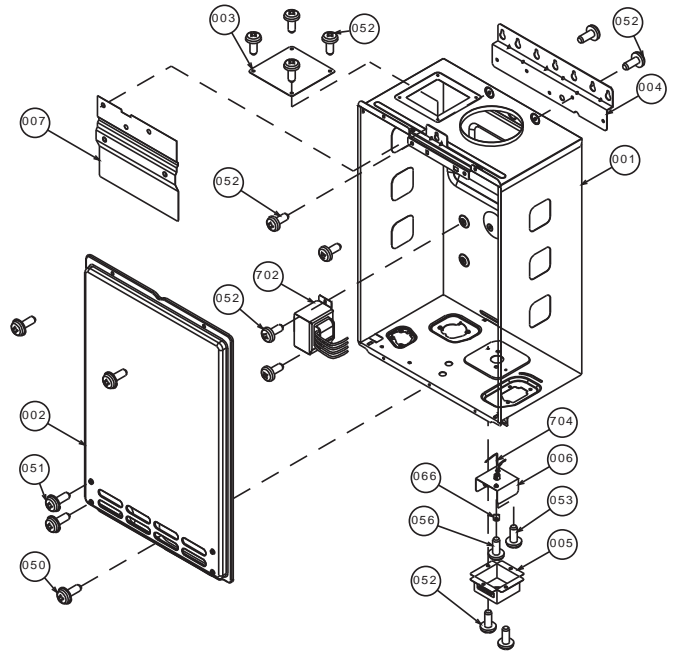

# Burner Assembly

110

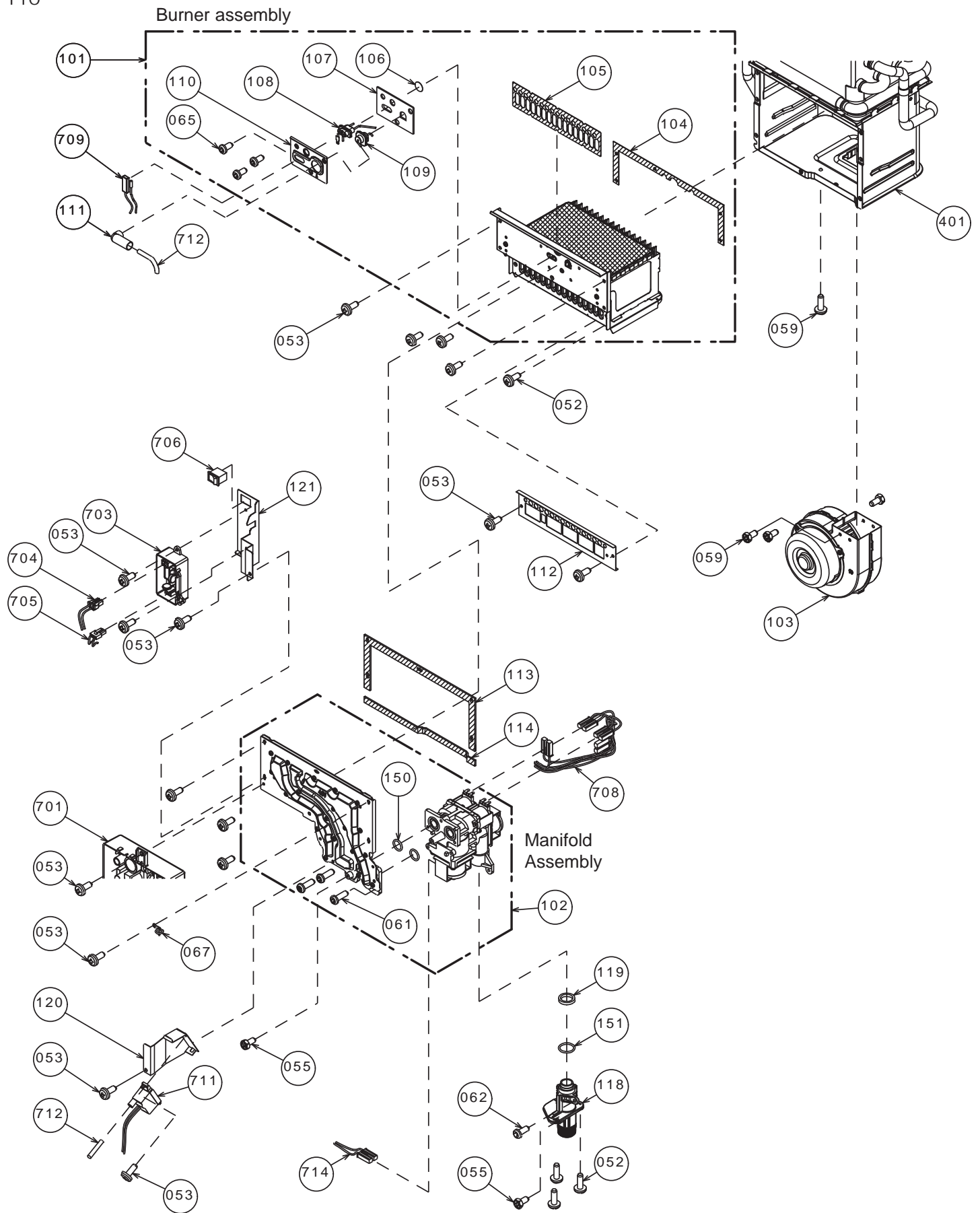

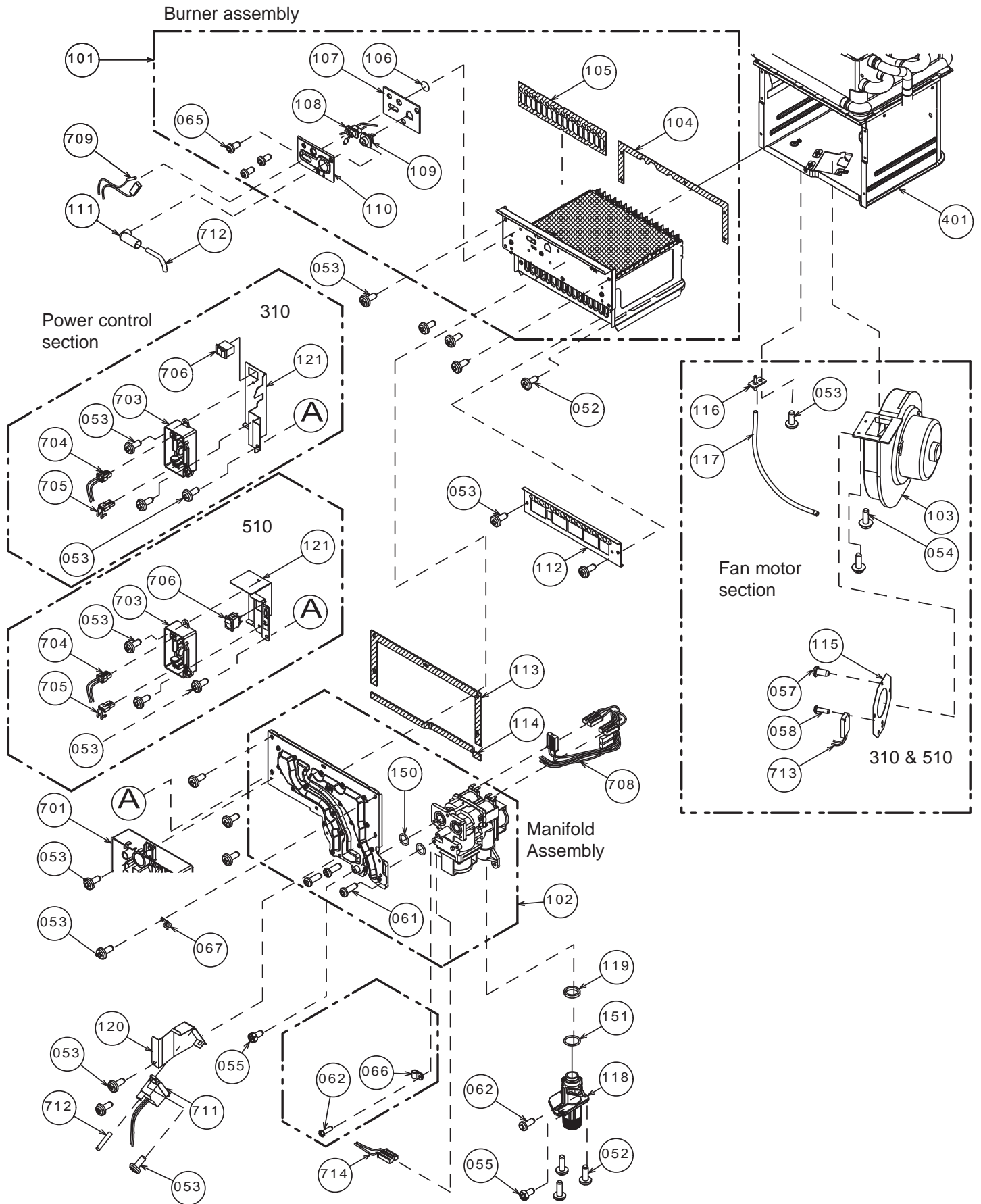



## Computer Board Assembly

110 & 310

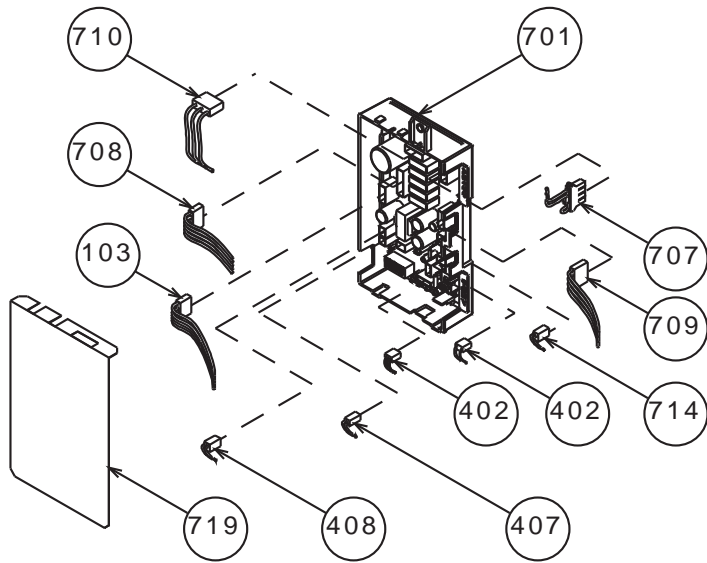

## Computer Board Assembly

510

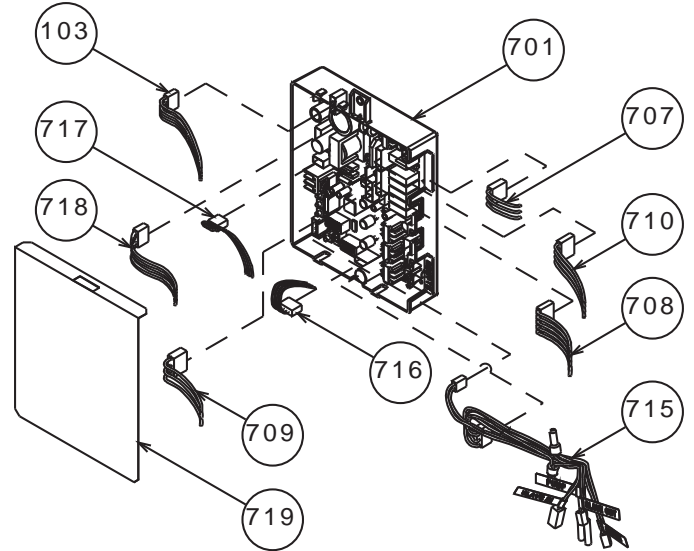

## Water Way Assembly

110

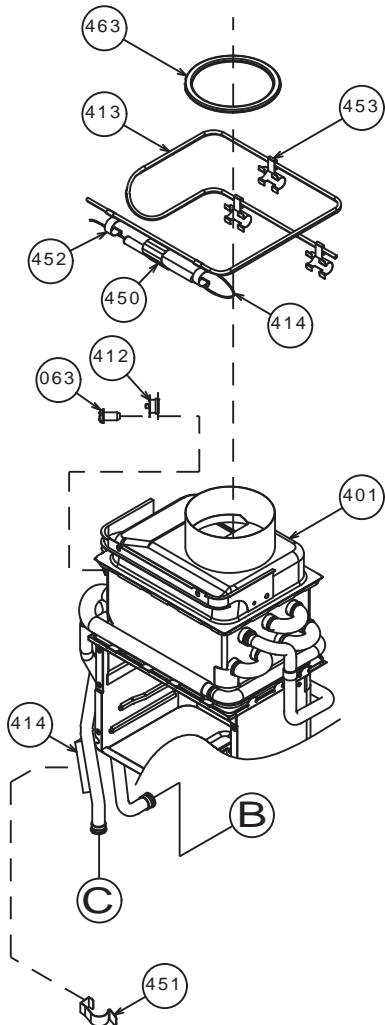

## Water Way Assembly

310

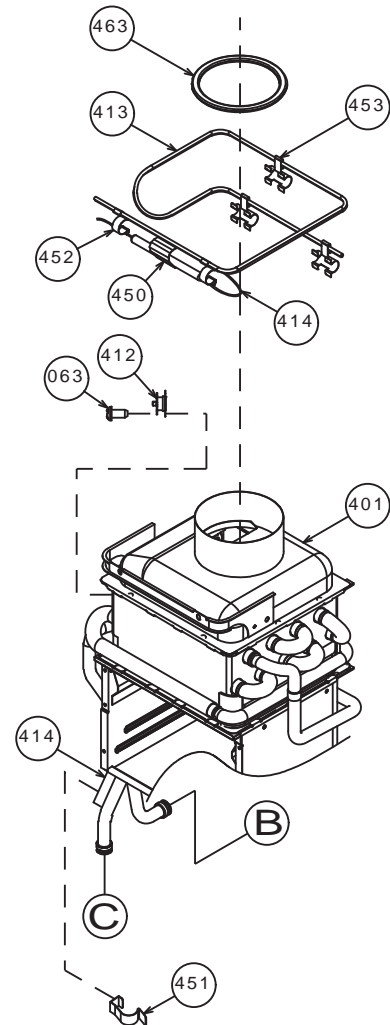

# Water Way Assembly

510

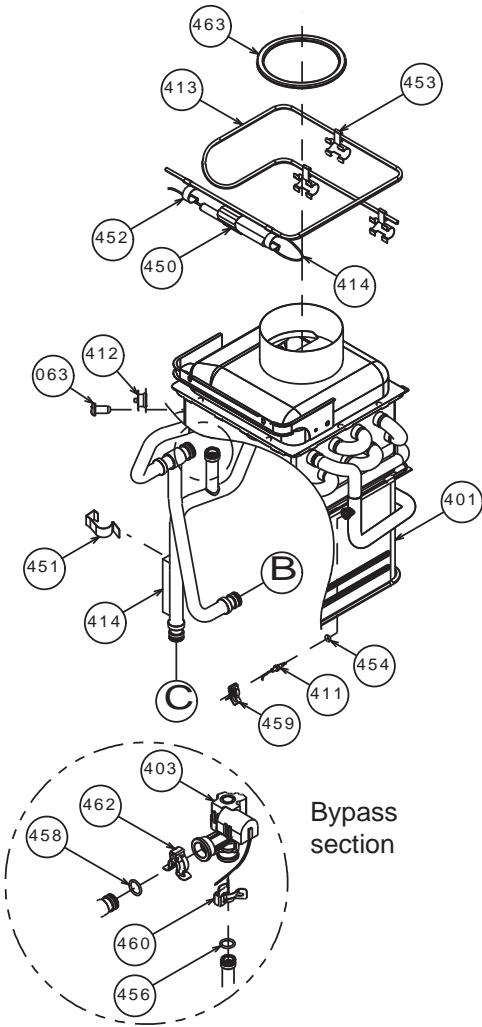

# Water outlet section

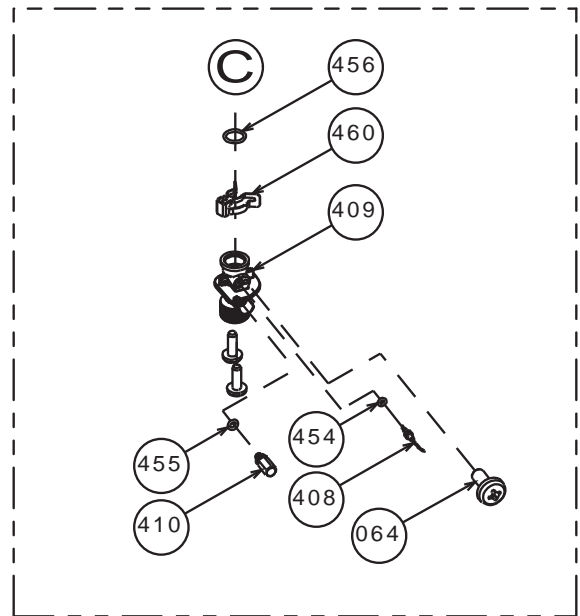

# Water inlet section

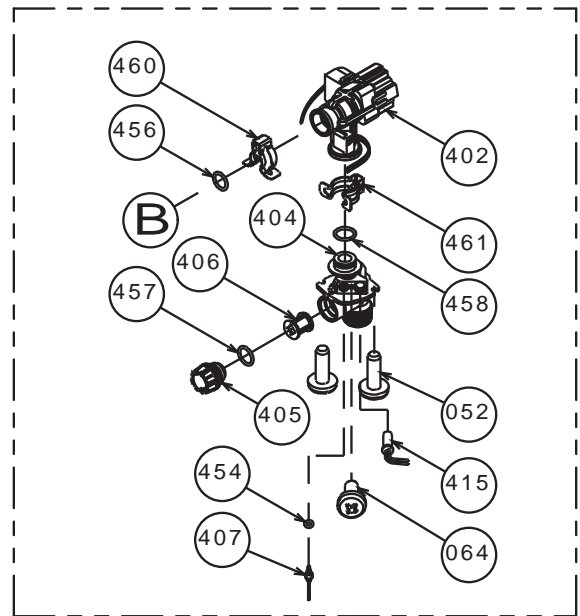

## PARTS LIST

Item #	Description	Part #
1	Case assembly for 110	EK415
	Case assembly for 310 & 510	EK402
2	Front cover for 110	EK419
	Front cover for 310	EK403
	Front cover for 510	EK434
3	Air blockage plate for 110, 310 & 510	EK401
4	Bracket	EKJ09
5	Junction box	EKJ64
6	Junction box inner plate	EKJ66
7	Back guard panel for 110	EX00M
	Back guard panel for 310 & 510	EKK5H
50	Screw M4x12 (w/Washer)	EW000
51	Screw M4x10 (w/Washer)	EW001
52	Screw M4x10 (Coated)	EW002
53	Screw M4x10	EW003
54	Hex head screw M4x12 (w/Washer)	EW004
55	Hex head screw M4x8	EW005
56	Screw M4x10	EX014
57	Screw M3x6 SUS3	EW00B
58	Screw M3x10	EW008
59	Pan screw M4x12 (w/Washer)	EW00H
60	Pan screw M4x10 FEZN	EW024
61	Tap tight screw M4x12 FEZN	EKK31
62	Pan screw M4x10	EW006
63	Screw M3x6	EW00A
64	Screw M4x6	EW009
65	Pan screw M4x8	EW00D
66	Nylon clamp	EC00X
67	Wire clamp 60	EM167
101	Burner assembly for 110	EK417
	Burner assembly for 310 & 510	EKH5W
102	Manifold with gas valve assembly LP for 110	EK429
	Manifold with gas valve assembly LP for 310 & 510	EKH6T
	Manifold with gas valve assembly NA for 110	EK421
	Manifold with gas valve assembly NA for 310 & 510	EKK5K
103	Fan motor for 110	EX02E
	Fan motor for 310 & 510	EKK25
104	Burner holder gasket for 110	EX00V
	Burner holder gasket for 310 & 510	EKK0G
105	Burner gasket	EKK2X

Item #	Description	Part #
106	Burner window	EKK2V
107	Rod holder gasket	EKK2W
108	Flame rod for 110	EX00R
	Flame rod for 310 & 510	EKK0E
109	Igniter rod for 110	EX00S
	Igniter rod for 310 & 510	EKK0F
110	Rod holder for 110	EX00U
	Rod holder for 310 & 510	EKK32
111	Rod cap	EKN61
112	Burner damper for 110	EK430
	Burner damper for 310 & 510	EK412
113	Manifold gasket A	EKK2Y
114	Manifold gasket B	EKK2K
115	Fan damper for 110	EK416
	Fan damper for 310 & 510	TU001
116	Pressure port for 310 & 510	EKK2D
117	Combustion chamber tube for 310 & 510	EKK2N
118	Gas inlet	EKK1E
119	Gas inlet ring	EKK2Z
120	Igniter plate	EKK1B
121	Surge box plate for 110 & 310	EKK4H
	Surge box plate for 510	EK436
150	O-ring P18 NBR (Black)	EZP18
151	O-ring P20 NBR (Black)	EK042
154	Exhaust port	EKK56
401	Heat exchanger assembly for 110	EK418
	Heat exchanger assembly for 310	EK406
	Heat exchanger assembly for 510	TU002
402	Flow adjustment valve/Flow sensor for 110 & 310	EK427
	Flow adjustment valve/Flow sensor for 510	EK438
403	Bypass valve for 510	EKK0U
404	Water inlet	EKK1U
405	Inlet drain plug	EKK2B
406	Inlet water filter	EKK2C
407	Inlet thermistor for 110 & 310	EKK4J
	Inlet thermistor for 510	EKK38
408	Outlet thermistor for 110 & 310	EKK55
	Mixing thermistor for 510	EKK1A
409	Water outlet	EKK1V
410	Outlet drain plug	EKK2E
411	Output thermistor for 510	EKK2T
412	Hi-Limit switch for 110 & 310	EM212
	Hi-Limit switch for 510	EKN34
413	Overheat-cut-off fuse	EK333

Item #	Description	Part #
414	Heater	EKK2R
415	Inlet heater	EKK2P
450	Pipe heater fixing plate	EKK27
451	Heater fixing plate 16	EK031
452	Fuse fixing plate 18	EKK26
453	Fuse fixing plate 14	EK029
454	O-ring P4 FKM	EZM04
455	O-ring P6 FKM	EZM06
456	O-ring P14 FKM	EZM14
457	O-ring P15 FKM	EZM15
458	O-ring P16 FKM	EZM16
459	Fastener "4-11" for 510	EKH30
460	Fastener "14-22"	EKK24
461	Fastener "16A"	EM192
462	Fastener "16-25A" for 510	EKK39
463	Silicon ring	EKN50
701	Computer board for 110	EK420
	Computer board for 310	EK414
	Computer board for 510	EK439
702	Transformer	EKH09
703	Surge box	EK428
704	AC120V wire for 110	EKK5M
	AC 120 V wire for 310 & 510	EKK3C
705	Transformer wire for 110	EK408
	Transformer wire for 310 & 510	EK440
706	AC120V Power ON-OFF switch	EKK4V
707	Switch wire for 110	EK407
	Switch wire for 310 & 510	EK441
708	Gas valve wire for 110 & 310	EKK3K
	Gas valve wire for 510	EKK10
709	Flame rod wire for 110	EK431
	Flame rod wire for 310	EKK3L
	Flame rod wire for 510	EKK11
710	EH-IG wire for 110 & 310	EKK3R
	EH-IG wire for 510	EKK0Z
711	Igniter	EKN74
712	High voltage igniter cable	EKK2M
713	Freeze protection thermostat for 110, 310 & 510	EKJ59
714	Proportional gas valve wire for 110 & 310	EKK58
	Proportional gas valve wire for 510	EKK12
715	Pump and multi cable for 510	EKK36
716	Thermistors wire for 510	EKK1Z
717	RS-VG wire for 510	EKK35
718	Water valves wire for 510	EKK33

Item #	Description	Part #
719	Computer board cover for 110 & 310	EKK49
	Computer board cover for 510	EKK1M

# OUTPUT TEMPERATURE CHART

Chart is based on properly sized gas line  
110 Models

### Output Temperature vs. GPM (Max. 6.6 GPM) with Various Inlet Water Temperature

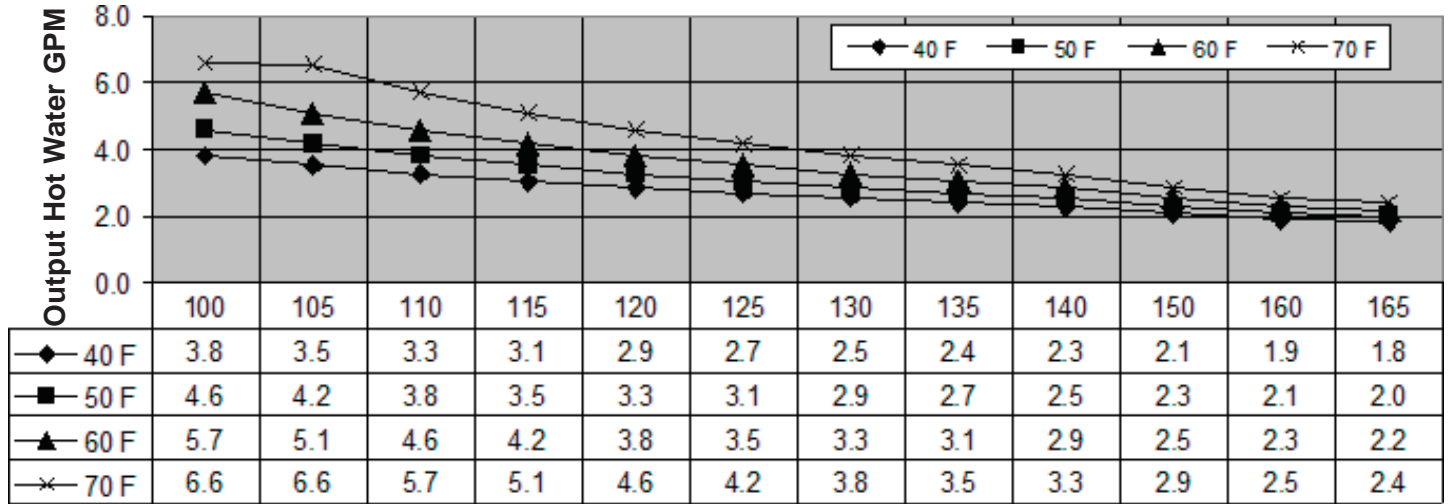

310 Models

### Output Temperature vs. GPM (Max. 8.0 GPM) with Various Inlet Water Temperature

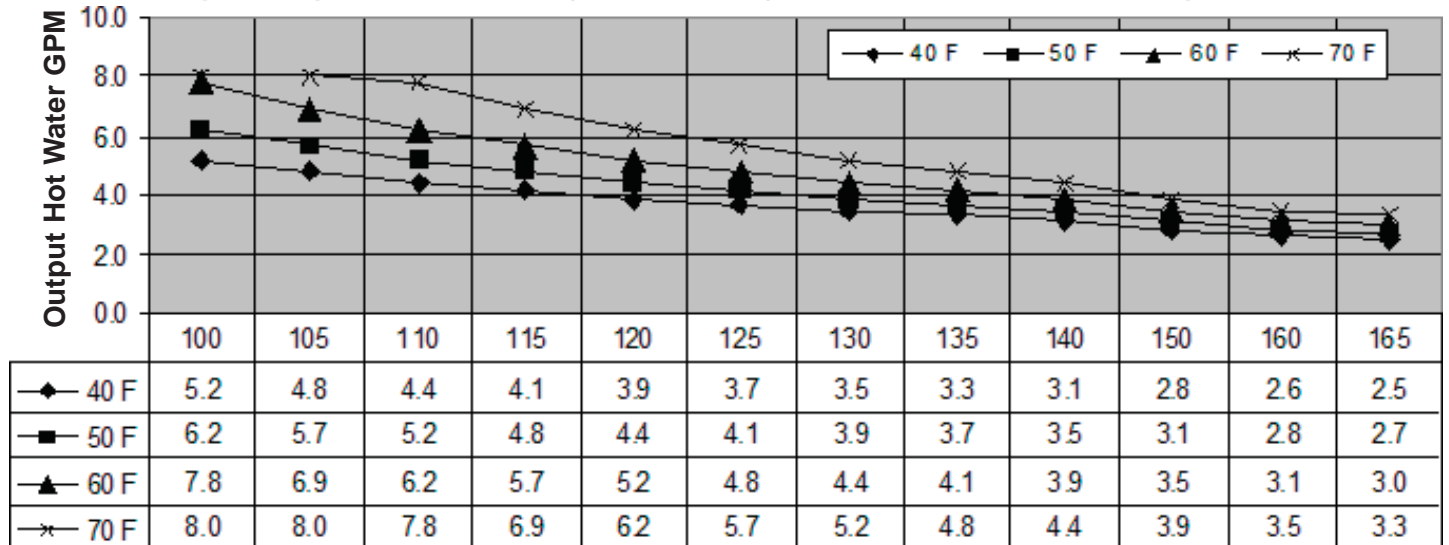

510 Models

### Output Temperature vs. GPM (Max. 10.0 GPM) with Various Inlet Water Temperature

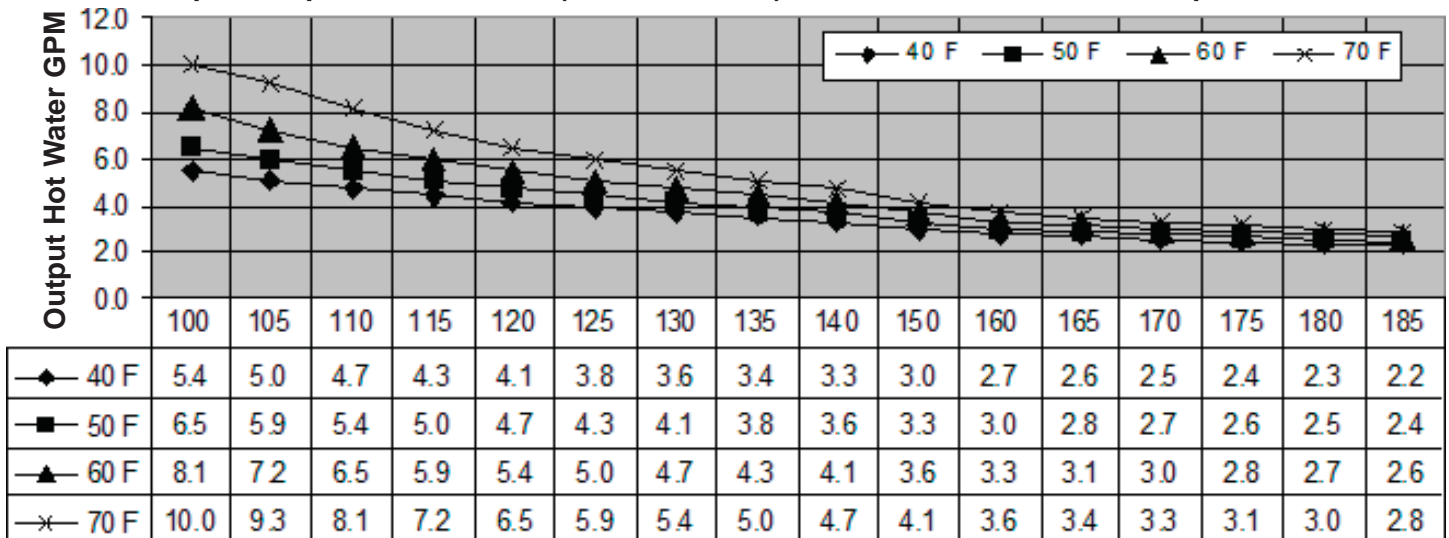

\*When the set temperature is 55°C (131°F) or higher, maximum flow rate is limited to 8.0 GPM.

## LIMITED WARRANTY

### 1. General terms of limited warranty:

This limited warranty gives you specific legal rights, and you may also have other rights which vary from State to State. The manufacturer will honor the warranty to the original retail buyer at the original location only, and it is not transferable.

THIS WARRANTY COVERS ONLY FAILED MECHANICAL AND ELECTRICAL PARTS DUE TO FACTORY DEFECTS UNDER NORMAL USAGE FOR THE PRODUCT'S INTENDED PURPOSES AND WITHIN THE APPLICABLE PERIOD SPECIFIED IN THE FOLLOWING TABLES. ONLY DIRECT DAMAGES SHALL BE RECOVERABLE BY A CLAIMANT UNDER THIS LIMITED WARRANTY AND, IN NO EVENT, WHETHER AS A RESULT OF BREACH OF CONTRACT, BREACH OF WARRANTY, TORT LIABILITY (INCLUDING NEGLIGENCE), STRICT LIABILITY, INDEMNITY OR OTHERWISE WILL BE LIABLE FOR ANY SPECIAL, INCIDENTAL, OR INDIRECT CONSEQUENTIAL DAMAGES INCLUDING PROPERTY DAMAGE, PERSONAL DAMAGES, LOSS OF USE, OR INCONVENIENCE. SOME STATES DO NOT ALLOW THE EXCLUSION OR LIMITATION OF INCIDENTAL OR CONSEQUENTIAL DAMAGES, SO THE ABOVE LIMITATION MAY NOT APPLY TO YOU.

### 2. Warranty for 510 models:

Application		HX <sup>(1)</sup>	Parts	Labor (Years)
Single Family Domestic Hot Water	No Recirculation		12	5
	On-Demand Recirculation <sup>(2)</sup>			
	w/ Standard Recirculation	Aquastat Control	5	3
		Pump Control		
		Timer Only		
No Pump Control (24 hr.)		3	3	
Commercial Or Multi-Family Domestic Hot Water	No Recirculation		5	5
	On-Demand Recirculation <sup>(2)</sup>			
	w/ Standard Recirculation	Aquastat Control	3	3
		Pump Control		
		Timer Only		
No Pump Control (24 hr.)		3	3	
Heating <sup>(4)</sup>	All Types	5	5	1 <sup>(3)</sup>

### Warranty for 110 & 310 models:

Application		HX <sup>(1)</sup>	Parts	Labor (Years)
Single Family Domestic Hot Water	No Recirculation		12	5
	On-Demand Recirculation <sup>(2)</sup>			
	w/ Standard Recirculation	Aquastat Control	3	3
		Pump Control		
		Timer Only		
No Pump Control (24 hr.)		1	1	
Multi-Family Domestic Hot Water	No Recirculation		3	3
	On-Demand Recirculation <sup>(2)</sup>			
	w/ Standard Recirculation	Aquastat Control	1	1
		Pump Control		
		Timer Only		
No Pump Control (24 hr.)		1	1	
Heating <sup>(4)</sup>	All Types	1	1	1 <sup>(3)</sup>
Commercial	All Types	1	1	1 <sup>(3)</sup>

(1) Heat exchanger

(2) An on-demand recirculation system is a system that utilizes either a push-button or other type of manual activation (as opposed to automatic activation with a temperature sensor or timer) to activate the circulation pump. An on-demand recirculation system can use either the existing cold water line as the return line or have its own dedicated return line.

(3) Limited Labor Coverage

- The manufacturer will provide for reasonable labor charges associated with warranty repairs or replacements within one (1) year from the date of purchase. The manufacturer will only pay directly to the service provider.
- Warranty service must be performed by an authorized Service Representative. A list of authorized Service Representatives is available upon request.



- All warranty claims and warranty service must be authorized and approved by the manufacturer.
- (4) Includes dual-purpose applications (combination heating and domestic).

3. Repair, Replacement or Refund:

The manufacturer or its authorized Service Representative will, at its sole discretion, repair or replace any failed or defective mechanical or electrical parts, or components thereof, or, if the manufacturer or its authorized Service Representative cannot replace said parts, and repair is not commercially practicable, the manufacturer or its authorized Service Representative will refund the purchase price. The manufacturer or its authorized Service Representative may, at its sole discretion, use new, refurbished or reconditioned parts.

4. Limitation on Duration of Implied Warranties:

ANY IMPLIED WARRANTIES ARISING UNDER STATE LAW, INCLUDING THE IMPLIED WARRANTIES OF FITNESS FOR A PARTICULAR PURPOSE AND MERCHANTABILITY, SHALL IN NO EVENT EXTEND PAST THE EXPIRATION OF ANY WARRANTY PERIOD HEREUNDER. SOME STATES DO NOT ALLOW LIMITATIONS ON HOW LONG AN IMPLIED WARRANTY LASTS, SO THE ABOVE LIMITATION MAY NOT APPLY TO YOU.

5. THIS WARRANTY WILL NOT COVER THE FOLLOWING:

- Any product that is not installed by a licensed plumber, gas installer, or contractor.
- Damages due to accidents, abuse, misuse, improper installation, misapplication, or incorrect sizing. Damages due to fires, flooding, freezing, electrical surges, or any Acts of God.
- Damages due to unauthorized alterations, attachments, and/or repairs.
- Damages due to a lack of maintenance (e.g. water filter, water treatment system, vent blockage, etc.)
- Any product installed in an improper environment (e.g. corrosive, dusty, chemically contaminated, excessive lint, etc.).
- Freeze damage that occurs without taking proper preventive measures as described in the installation manual.
- Condensate damage due to improperly installed or lack of a condensate trap (drain).
- Any product not installed in compliance with all applicable local & provincial codes, ordinances, and good trade practices.
- Any product sold to or installed in areas outside of Canada.
- Any product installed in applications that cause the water heater to activate more than 300 times per day (this averages to an activation every 5 minutes in a 24-hour period).
- Any failures that are not due to defects in materials or workmanship (mechanical and/or electrical parts).
- Damages due to improper installation:
  - Gas: incorrect gas pipe sizing, incorrect gas meter sizing, incorrect gas type, and/or gas pressures that fall outside the product's specified range.
  - Water: incorrect water pipe sizing, water pressures that fall outside the product's specified range, recirculation flow rates that fall outside the product's specified range (air removal), and/or lack of proper methods of air removal in a closed-loop, circulation system (see installation manual for details).
  - Electric: supply power voltages that fall outside the product's specified range.
- Damages due to water quality:
  - Introduction of liquids other than potable water or potable water / glycol mixtures into the product.
  - Introduction of pool water, spa water, or any chemically treated water into the product.
  - Introduction of hard water measuring more than 7 grains per gallon (120 ppm) for single family domestic applications or more than 4 grains per gallon (70 ppm) for all other types of applications into the product.

If you have any questions,  
please call or write to:  
GSW Water Heating  
599 Hill Street West  
Fergus, ON Canada N1M 2X1  
Toll Free: 1-888-479-8324