

## 6. Wiring diagram

The diagram below refers to both the T-K4-IN and T-K4-OS.

BK: BLACK R: RED BL: BLUE Y: YELLOW LB: LIGHT BLUE  
W: WHITE G: GREEN O: ORANGE BR: BROWN P: PURPLE

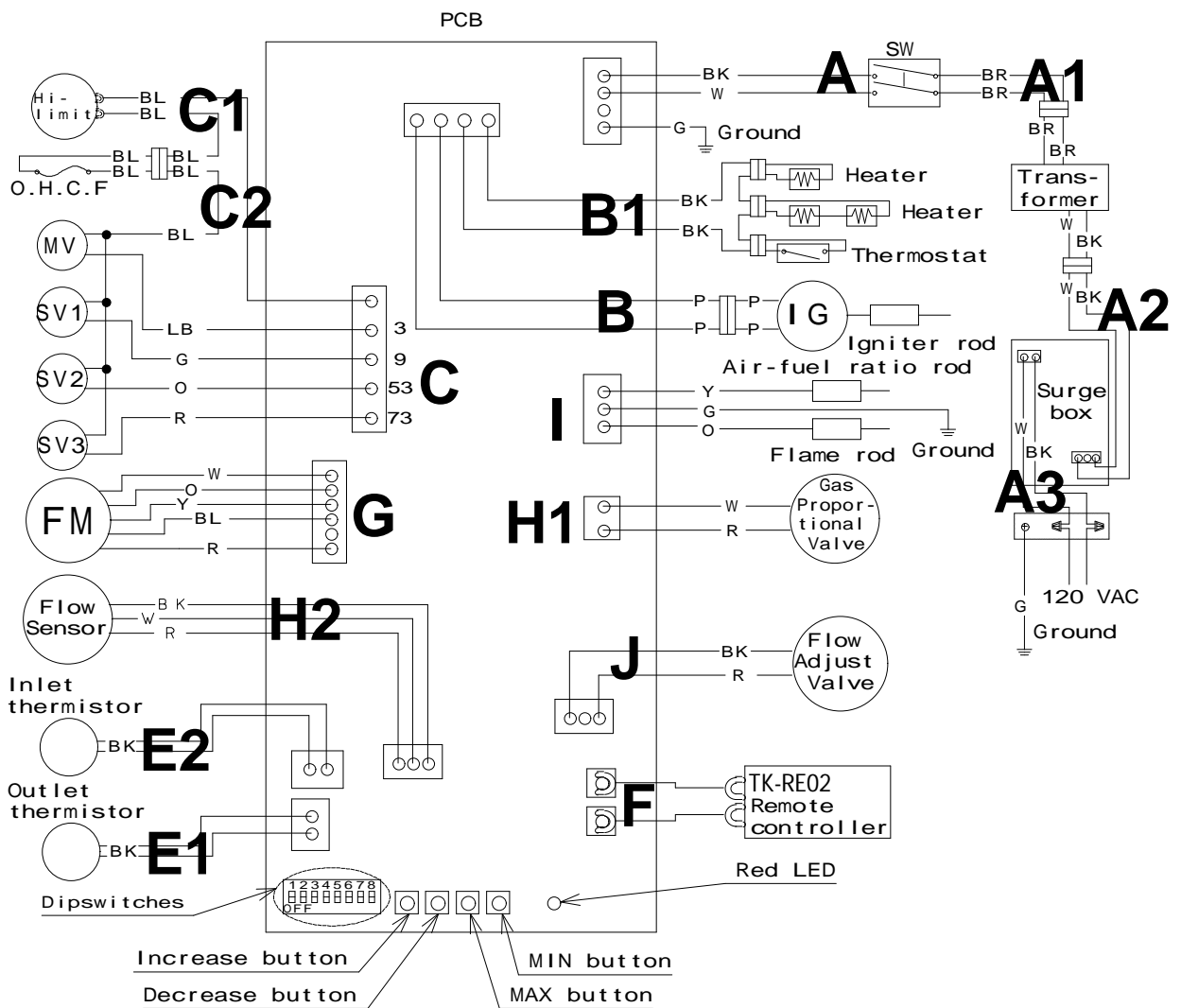

## ***7. Wiring diagram check points for diagnosis***

The table below applies to both the T-K4-IN and T-K4-OS.

Check-point	Part and Description	Color of wires	Normal range
A, A1	100V Power supply	White – Black (A) Brown – Brown (A1)	90 to 110 VAC
A2,A3	120V Power supply	Black - White	108 to 132 VAC
B	Igniter	Purple - Purple	90 to 110 VAC
B1	Heater	Black - Black	90 to 110 VAC
C	Gas valves	Light blue - blue at COM (MV)	78 to 100 VDC (during operation) / 0.9 to 1.3 k $\Omega$
		Green - blue at COM (SV1)	78 to 100 VDC (during operation) / 1.3 to 1.9 k $\Omega$
		Orange - blue at COM (SV2)	78 to 100 VDC (during operation) / 1.3 to 1.9 k $\Omega$
		Red - blue at COM (SV3)	78 to 100 VDC (during operation) / 0.9 to 1.7 k $\Omega$
C1	Hi-limit switch	Blue - Blue	Less than 1 VDC and less than 1.0 $\Omega$
C2	Overheat cutoff fuse	Blue - Blue	Less than 1 VDC and less than 1.0 $\Omega$
E1	Outlet thermistor	Black - Black	See table on p. 14
E2	Inlet thermistor	Black - Black	
F	Remote controller	*	11 to 25 VDC
G	Fan motor	Red - Blue	110 to 160 VDC
		Yellow - Blue	13 to 17 VDC
		Orange - Blue	2 to 6.5 VDC

Check-point	Part and Description	Color of wires	Normal range
H1	Gas proportional valve	White - red	1 to 15 VDC (during operation) and 20 to 40 $\Omega$
H2	Flow sensor	Red - Black	4 to 5.5 VDC
		White - Black	1 to 4 VDC (pulse) 1,080 pulse / min (more than 18 Hz)
I	Air-fuel ratio rod	Yellow - AFR rod (Between AFR rod and the computer board)	More than 0.5 $\mu$ A (during operation)
	Flame rod	Orange - Flame rod (Between flame rod and the computer board)	More than 1 $\mu$ A (during operation)
J	Flow adjustment valve	Red - Black	7 to 16 VDC and 0.09 to 0.2 k $\Omega$