

NON-CONDENSING CONCENTRIC VENT

Fully modulating, gas fired, tankless water heater with sealed combustion and power vented flue. Supplies hot water to domestic hot water systems (directly or indirectly) and can be used with water storage tanks, recirculation systems, and/or combined domestic hot water & space heating applications.

FEATURES:

CONCENTRIC VENT DESIGN

FIELD CONVERTIBLE FROM NATURAL GAS TO PROPANE

MAXIMUM FLOW RATES UP TO 10.0 GPM

COPPER HEAT EXCHANGER

- 25x better heat transfer than stainless steel thus stabilizing outgoing water temperature quicker and reducing pressure drop across the heat exchanger
- Easy-Link up to 4 units (no additional parts or accessories needed)
- Multi-link up to 20 units (with a Multi-Unit Controller)

COMPLIES WITH LEAD FREE STANDARDS

SAFETY FEATURES:

- Built-in freeze protection
- Manual reset hi limit (up to 194°F)
- Overheat cutoff fuse
- Inlet and outlet thermistors for constant temperature monitoring
- Air fuel ratio rod
- Flame sensor

VENTING AND COMBUSTION

- 3"/5" direct vent APNC35 concentric vent system
- Vertical or horizontal vent termination installation
- 43' max length, 4 elbows max 90° elbows = 5' equivalent length)
- Power direct vent
- Electronic ignition - no pilot light

WARRANTY

- 15-year limited warranty on heat exchanger in residential applications
- 5-year limited warranty on heat exchanger in commercial applications
- 5-year limited warranty on all parts



ATI-110C, ATI-310C, ATI-510C



(510C models only)



ANSI Z21.10.3

FLOW RATE vs TEMPERATURE RISE

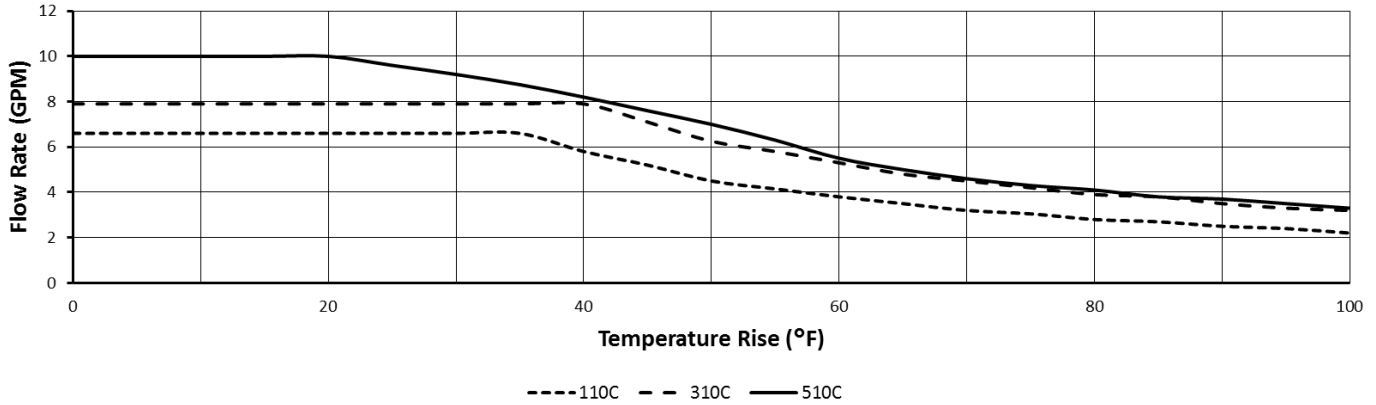

*Maximum flow rate with set temperature above 131°F (55°C) is 8.0 GPM.

PRESSURE LOSS vs FLOW RATE

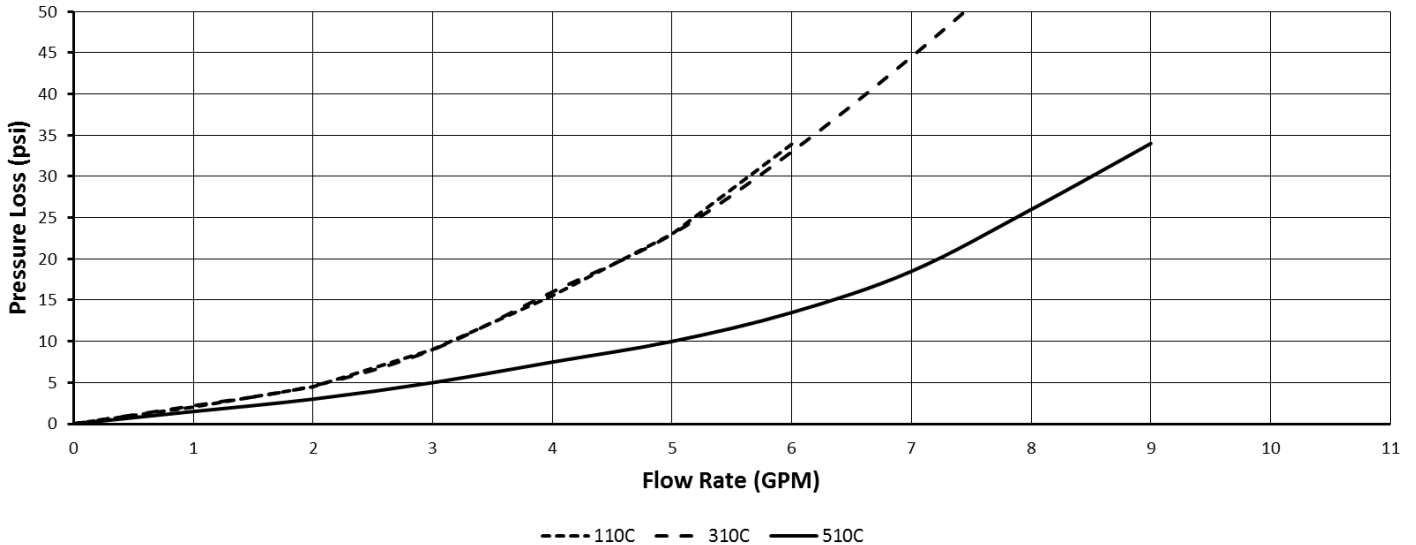



Residential Tankless Gas Water Heaters

OPTIONAL ACCESSORIES

PART NUMBER	DESCRIPTION
100112156	Isolation Valve Kit
100209924	Remote Control
100113154	Product Preserver
100112691	Multi-Unit Controller

SUGGESTED SPECIFICATION

Water heater(s) shall be the fully modulating, non-condensing gas fired A. O. Smith tankless water heater model _____, having a maximum input rating of _____ BTU/h. The heater shall have 3/4" male NPT water and gas connections. The inlet gas supply pressures shall be _____ in. WC (minimum) up to _____ in. WC (maximum) for _____ fuel. The heater shall incorporate an integrated temperature controller that will provide diagnostic information, fault history, and heater set temperature. The heater shall operate using 120V/60Hz power and will incorporate a factory-installed power cord.

The water heater(s) shall be direct vented with 3" /5" APNC35 concentric vent with a length not to exceed 43 equivalent feet, terminating horizontally or vertically with no more than four (4) 90° elbows.

The water heater(s) shall use a commercial grade copper alloy, fin tube primary heat exchanger with quick release brass or bronze waterways. The heater(s) shall be controlled by an onboard solid-state printed circuit board which uses thermistors to monitor inlet and outlet water temperature and exhaust temperature, a flow sensor to measure flow rate, a flame sensor to monitor combustion, and an air-fuel ratio rod to measure and adjust operation in order to maintain optimal combustion efficiency. The heater(s) shall also consist of inline fusing and surge absorbers for electrical surge protection, an electronic spark igniter, aluminized stainless steel burners, hi-limit temperature switch to monitor water temperature, modulating gas valve, an overheat cutoff fuse, and incorporate ceramic heating blocks and an auto-fire system for freeze protection of the heat exchanger and water piping.

The water heater(s) shall be design certified by CSA according to ANSI Z21.10.3 *CSA 4.3 and meet the energy efficiency requirements of NRCan and the current edition of ASHRAE 90.1.

MODEL NUMBER	FUEL TYPE	GAS CONSUMPTION INPUT		INLET GAS PRESSURE*		ENERGY FACTOR (EF)	FLOW RATE**		HOT/COLD CONNECTIONS	GAS CONNECTION	DIMENSIONS IN (CM)			UNIT WEIGHT LB (KG)
		MINIMUM BTU/h	MAXIMUM BTU/h	MINIMUM IN. W.C.	MAXIMUM IN. W.C.		@30°F RISE	@70°F RISE			HEIGHT	WIDTH	DEPTH	
ATI-110C-N	Natural	15,000	140,000	5.0	10.5	0.82	6.6	3.3	¾" NPT	¾" NPT	20 ½ (52)	13 ¾ (35)	10 ½ (27)	51 (23)
ATI-310C-N	Natural	15,000	190,000	5.0	10.5	0.82	8	4.5	¾" NPT	¾" NPT	20 ½ (52)	13 ¾ (35)	10 ½ (27)	51 (23)
ATI-510C-N	Natural	15,000	199,000	5.0	10.5	0.82	10	4.7	¾" NPT	¾" NPT	20 ½ (52)	13 ¾ (35)	10 ½ (27)	51 (23)

15-150 psi water pressure. 40 psi or above recommended for maximum flow.

*For Propane, minimum inlet gas pressure is 8.0 in. W.C. and maximum inlet gas pressure is 14.0 in. W.C.

**Current numbers based on factory testing; 0.5 GPM required for activation; 0.4 GPM required for continuous fire after initial ignition.

Models are certified from sea level to 10,100 ft. (3,078 m) elevations.

MODEL DIMENSIONS

CLEARANCES: TOP 12", BOTTOM 12", FRONT* 4", BACK 0.5", SIDES 3"

*Recommended 24" clearance from the front of the unit for maintenance.

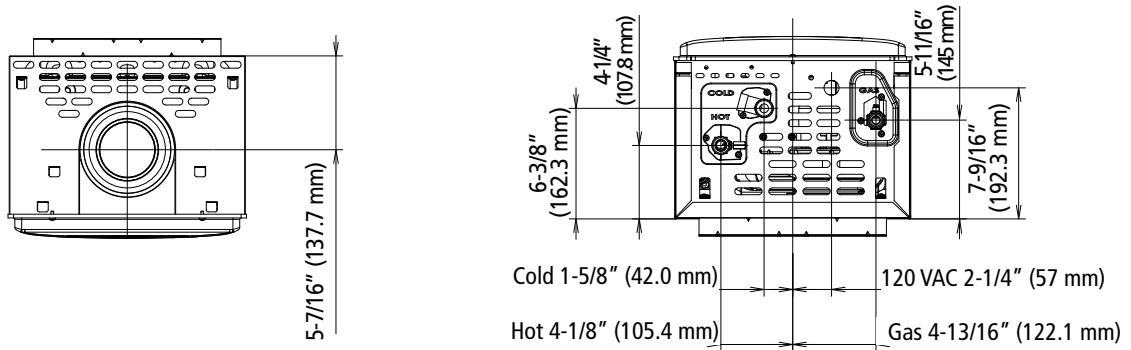

Top View

Bottom View

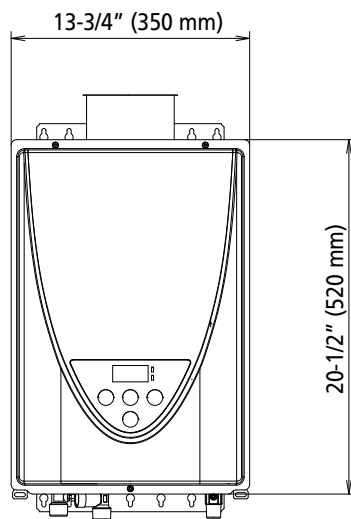

Front View

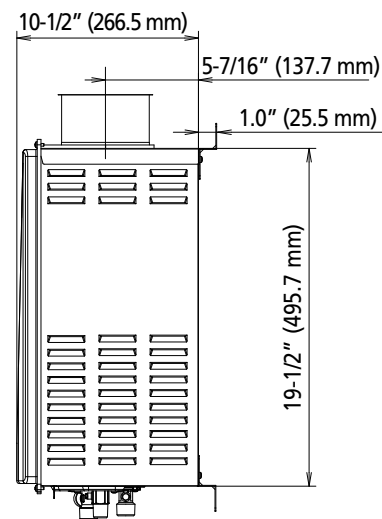

Side View

For Technical Information call 888-599-2837. A. O. Smith Enterprises Ltd. reserves the right to make product changes or improvements without prior notice.