

## CONSERVATIONIST™ DURACLAD OIL-FIRED TANK TYPE WATER HEATER

**MEETS THE THERMAL EFFICIENCY AND STANDBY LOSS REQUIREMENTS OF THE U.S. DEPARTMENT OF ENERGY AND CURRENT EDITION ASHRAE/IESNA 90.1**

### LIME TAMER™ MODELS INHIBIT LIME AND SEDIMENT BUILDUP

- Lime Tamer™ models are warranted against

### GLASSLINED TANK

- Maximizes tank life. 160 psi working pressure.

### 180°F ADJUSTABLE THERMOSTAT

- Has upper and lower sensing bulbs to average water temperatures at top and bottom of heater for maximum temperature control (120°-180°F).

### SAFETY SHUTOFF

- Limits temperature buildup.

### UL LISTED OIL BURNER

- Precision engineered to match the units they are used with; designed to fire 1.75 to 5.0 gallons of oil per hour. All models equipped with single phase continuous duty motor 120 volt AC60 Hz, 3450 rpm with manual overload switch and interrupted ignition. Standard burners equipped with single stage pump with 1 or 2 line capability. Flame retention principle assures high rate of combustion efficiency, yet maintains low operating noise levels. Fuel unit includes pump, strainer, pressure regulating valve and ignition transformer. Transformer rated at 120 volt AC, 60 Hz with 10,000 volt secondary, UL listed for use with No. 1 and 2 commercial grade fuel oil. Burner mounted cadmium cell relay for flame detection - 15 second safety switch timing eliminates the need for RA890F Electronic Safeguard. Complies with UL A708.5-32/33.

### EFFICIENT COMBUSTION CHAMBER

- Precast, high temperature combustion chamber made of alumina silica ceramic fiber. Engineered for maximum insulation and heat reflection. Unique design assures more complete combustion by stabilizing flame pattern.

### INTERRUPTED IGNITION

- Reduces electrical consumption.

### OIL SOLENOID SAFETY VALVE

- Standard on COF-455 and 700.

### 3/4" DRAIN VALVE

- Provided in lower tank for fast draining.

### TWO HAND-HOLE CLEANOUTS

- Allows easy cleaning on standard models COF-385 and larger and ASME models.

### ANODIC PROTECTION

- For longer tank life.

### FLAME OBSERVATION PORT

- Permits convenient flame check.

### FOAM INSULATION

- Saves fuel, helps maintain constant temperature.

### JACKET

- Heavy gauge steel with baked enamel finish over bonderized undercoat. Not approved for installation on combustible flooring.

### EASY TO INSTALL BURNER

- Three bolt mounting of burner assures easy installation.

### BAROMETRIC DRAFT REGULATOR

### CSA CERTIFIED AND ASME RATED T&P RELIEF VALVE

### OTHER FEATURES

- Two Stage Pump - For use with underground oil storage tanks or JP-5 fuel
- ASME construction available on select models - All models are rated 160 psi max working pressure
- CAUTION: Units must be installed on noncombustible surface.

### 3-YEAR LIMITED TANK / 1-YEAR LIMITED PARTS WARRANTY

- Factory Start-Up included - Required for activating warranty and assuring maximum operating performance. Contact your local sales representative or Authorized Start-Up Agent to arrange a FREE Certified Start-Up.
- For complete warranty information, consult written warranty or go to hotwater.com.



MODELS COF-199 THROUGH COF-700(A)



1" NPT T&P RELIEF VALVE  
(FRONT OF HEATER)

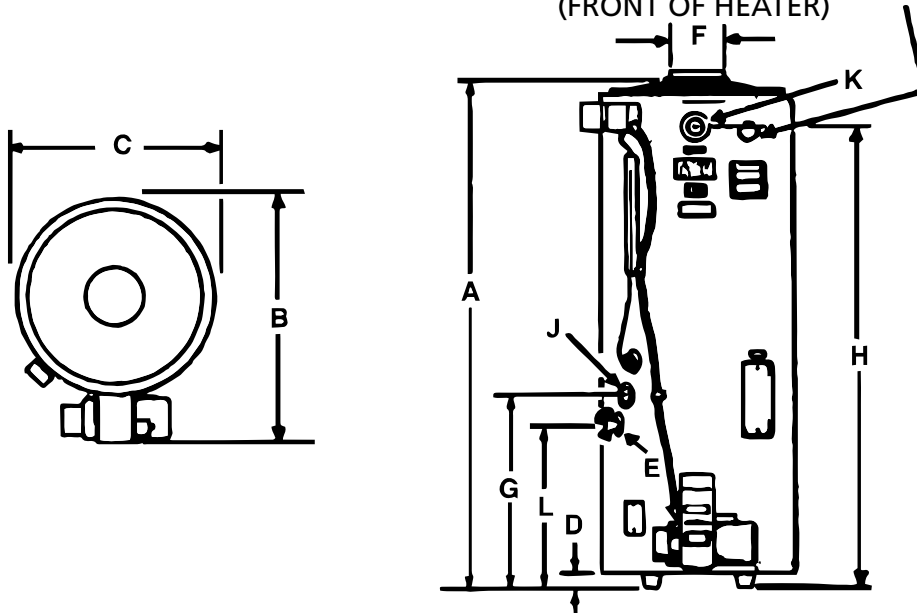

Model Number	Dimensions in Inches												Approx. Shipping Weight (lbs)	
	A	B	B	D	E	F	G	H	I	J	K	L	Standard	ASME
COF-199*	74-1/2	36-3/4	27-3/4	2	3/4 NPT	6	26-5/8	74-1/2	1-1/2 NPT	1-1/2 NPT	22-3/4	553	N/A	—
COF-245	74-1/2	36-3/4	27-3/4	2	3/4 NPT	8	26-5/8	74-1/2	1-1/2 NPT	1-1/2 NPT	22-3/4	554	N/A	—
COF-315 (A)	74-1/2	36-3/4	27-3/4	2	3/4 NPT	8	26-5/8	74-1/2	1-1/2 NPT	1-1/2 NPT	22-3/4	554	657	668
COF-385(A)	73-3/4	36-3/4	27-3/4	2	3/4 NPT	8	24-3/4	73-3/4	1-1/2 NPT	1-1/2 NPT	23-7/16	624	742	730
COF-455(A)	73-3/4	36-3/4	27-3/4	2	3/4 NPT	8	24-3/4	73-3/4	1-1/2 NPT	1-1/2 NPT	23-7/16	700	747	748
COF-700(A)	73-3/4	36-3/4	27-3/4	2	3/4 NPT	10	30-3/16	79-3/16	1-1/2 NPT	1-1/2 NPT	28-7/8	739	822	853

Model Number	Gallon Capacity	Firing Rate GPH	Input* BTU/h	RECOVERY RATES AT °F RISE											Motor HP	Model Number	Vent Diameter	
				40	50	60	70	80	90	100	110	120	130	140			Inches	Millimeters
COF-199*	86	1.42	199,000	482	386	322	276	241	214	193	175	161	148	138	1/8	COF-199*	6	152.4
COF-245	86	1.75	245,000	594	475	396	339	297	264	238	216	198	183	170	1/8	COF-245	8	203.2
COF-315(A)	84	2.25	315,000	764	611	509	436	382	339	305	278	255	235	218	1/8	COF-315(A)	8	203.2
COF-385(A)	75	2.75	385,000	933	747	622	533	467	415	373	339	311	287	267	1/8	COF-385(A)	8	203.2
COF-455(A)	75	3.25	455,000	1103	882	735	630	552	490	441	401	368	339	315	1/8	COF-455(A)	8	203.2
COF-700(A)	69	5.00	700,000	1697	1358	1131	970	848	754	679	617	566	522	485	1/8	COF-700(A)	10	254

Based on No. 2 fuel oil. Capacity rating are actual heater performance at 80% thermal efficiency.  
NOTE: Above 2000' altitude, input ratings should be reduced 4% for each 1000' above sea level.

\* These models are factory supplied with a flue reducer that must be installed on the top cover.

### SUGGESTED SPECIFICATION

Water heater(s) shall be commercial oil model number \_\_\_\_\_ or equivalent. Heater(s) shall have a minimum oil firing rate of \_\_\_\_\_ gph at 100°F temperature rise and a storage capacity of \_\_\_\_\_ gallons. The 160 psi working pressure tank shall be glass-lined with the alkaline borosilicate composition being fused to the steel at 1600°F and be equipped with 1 1/2" water inlet and outlet openings, and 2 3/4" x 3 3/4" boiler-type hand-hole cleanout (2) on COF-315 and larger or ASME models. The tank shall be insulated with 2" fiber glass insulation. The outer jacket shall have baked enamel finish over a bonderized undercoating. The burner shall be Underwriters' Laboratories listed and have a \_\_\_\_\_ (one or two) stage oil pump. The burner shall have flame retention, interrupted ignition and be equipped with primary controls which will provide for 15 second safety shutdown in the event of flame failure. The heater(s) shall be factory equipped with temperature limiting device, drain valve, flame observation port and 180°F adjustable thermostat having upper and lower sensing bulbs which average the water temperatures at the top and bottom of the tank for maximum water temperature control. A CSA Certified and ASME Rated T&P Relief Valve shall be furnished and installed by the factory. Heater tank shall have a 3 year limited warranty against corrosion and tank failure due to sediment buildup as outlined in the warranty. Fully illustrated factory installation Manual.

For Technical Information call 888-599-2837. A. O. Smith Enterprises Ltd. reserves the right to make product changes or improvements without prior notice.