

# POLARIS

## Polaris™ High-Efficiency Commercial Gas Water Heater

Polaris™ has a high grade 444 stainless steel tank with brass connections for years of dependable, trouble-free service - no anode required. A submerged combustion chamber with spiral flue provides up to 96% thermal efficiency and ultra-low standby heat loss of approximately 1%.

### CONDENSING DESIGN

- Helical internal heat exchanger keeps hot combustion gases in the tank longer to transfer more heat into the water

### MODULATING GAS BURNER

- Maintains high efficiency operation at lower input rates

### SEALED COMBUSTION WITH WOVEN FIBRE PREMIX BURNER

- Metal fibre burner is designed for clean combustion in high-intensity blue flame mode
- Uniform combustion provides excellent heat transfer
- Manufactured of refractory steel that resists corrosion and provides excellent resistance to thermal and mechanical shock, even at extreme temperatures

### WHISPER QUIET OPERATION

- Ultra quiet blower and burner minimize noise
- Requires 120 volt 60Hz power supply and draws less than 5 Amps

### POWER DIRECT VENT USING 2" OR 3" PLASTIC PIPE

- Direct vents up to 130 equivalent feet using ULC S636 PVC or CPVC pipe either through the wall or through the roof
- Optional concentric vent kit available

### ADVANCED ELECTRONIC CONTROL

- Large touchscreen display
- Precise temperature control
- Advanced water heater status and diagnostics

### FULL SERVICEABILITY FROM THE FRONT

- Removal of two front access panels exposes all serviceable components
- Modular components are easily removed

### SIDE-MOUNTED HOT AND COLD RECIRCULATING TAPS

- For installations with a recirculation system or as part of a combined domestic hot water and space heating system

### AVAILABLE IN NATURAL GAS OR PROPANE

### DESIGN CERTIFIED BY CSA INTERNATIONAL TO CURRENT EDITION OF ANSI Z21.10.3/CSA 4.3

### WARRANTY

- 3 years limited tank warranty
- 1 year limited parts warranty



For Technical Information call 888-599-2837. A. O. Smith Enterprises Ltd. reserves the right to make product changes or improvements without prior notice.



# Polaris™ High-Efficiency Commercial Gas Water Heater

## PERFORMANCE

Model	Series	Capacity		Maximum Certified Altitude	Input	Recovery Rate at 90°F Temperature Rise	Thermal Efficiency	Warranty Tank/Parts
		USG	L					
<b>NATURAL GAS</b>								
PC 34-130 N	200	34	129	7,700 (2,437)	130,000	168 (636)	96%	3/1
PC 34-150 N	200	34	129	7,700 (2,437)	150,000	190 (719)	94%	3/1
PC 50-130 N	200	50	189	7,700 (2,437)	130,000	165 (625)	95%	3/1
PC 50-150 N	200	50	189	7,700 (2,437)	150,000	190 (719)	95%	3/1
PC 50-175 N	200	50	189	7,700 (2,437)	175,000	222 (840)	96%	3/1
PC 50-199 N	200	50	189	7,700 (2,437)	199,000	253 (958)	96%	3/1

For propane models sub N with P. Natural gas models are series 200. Propane models are series 201. All models comply with national energy efficiency regulations. Input, output and recovery may vary depending upon air inlet and exhaust outlet installations, consult manual for details.

## DIMENSIONS & SHIPPING WEIGHT

Model	Height to Top of Tank	Tank Diameter	Height to Lower Side Connection	Height to Cold Water Inlet	Height to Upper Side Connection	Height to T&P	Height to Gas Supply	Height to Air Inlet	Water Connections	Gas Connections	Vent Diameter	Shipping Weight
	A IN (CM)	B IN (CM)	C IN (CM)	C IN (CM)	D IN (CM)	E IN (CM)	F IN (CM)	G IN (CM)	IN NPT	IN NPT	IN	LB (KG)
<b>NATURAL GAS</b>												
PC 34-130 N	48 ½ (123)	22 (56)	15 ¾ (40)	15 ¾ (40)	40 ½ (103)	41 (104)	6 ¾ (16)	6 ¾ (16)	1	½	2 or 3	150 (68)
PC 34-150 N	48 ½ (123)	22 (56)	15 ¾ (40)	15 ¾ (40)	40 ½ (103)	41 (104)	6 ¾ (16)	6 ¾ (16)	1	½	2 or 3	150 (68)
PC 50-130 N	62 ¾ (158)	22 (56)	15 ¾ (40)	15 ¾ (40)	54 ½ (138)	55 (140)	6 ¾ (16)	6 ¾ (16)	1	½	2 or 3	176 (80)
PC 50-150 N	63 ¾ (162)	22 (56)	15 ¾ (40)	15 ¾ (40)	55 ¾ (142)	56 ¼ (143)	6 ¾ (16)	6 ¾ (16)	1	½	2 or 3	180 (82)
PC 50-175 N	63 ¾ (162)	22 (56)	15 ¾ (40)	15 ¾ (40)	55 ¾ (142)	56 ¼ (143)	6 ¾ (16)	6 ¾ (16)	1	½	3	180 (82)
PC 50-199 N	63 ¾ (162)	22 (56)	15 ¾ (40)	15 ¾ (40)	55 ¾ (142)	56 ¼ (143)	6 ¾ (16)	6 ¾ (16)	1	½	3	180 (82)

## OPTIONAL KITS

Description	Part Number
2" Concentric vent kit	100093946
3" Concentric vent kit	100093947

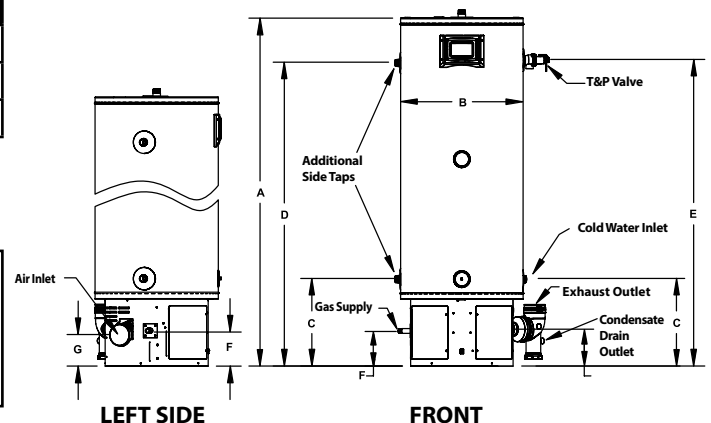
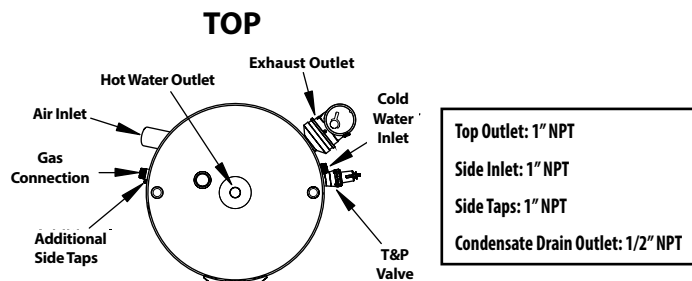

For Technical Information call 888-599-2837. A. O. Smith Enterprises Ltd. reserves the right to make product changes or improvements without prior notice.