

# SCHÉMA DE CÂBLAGE

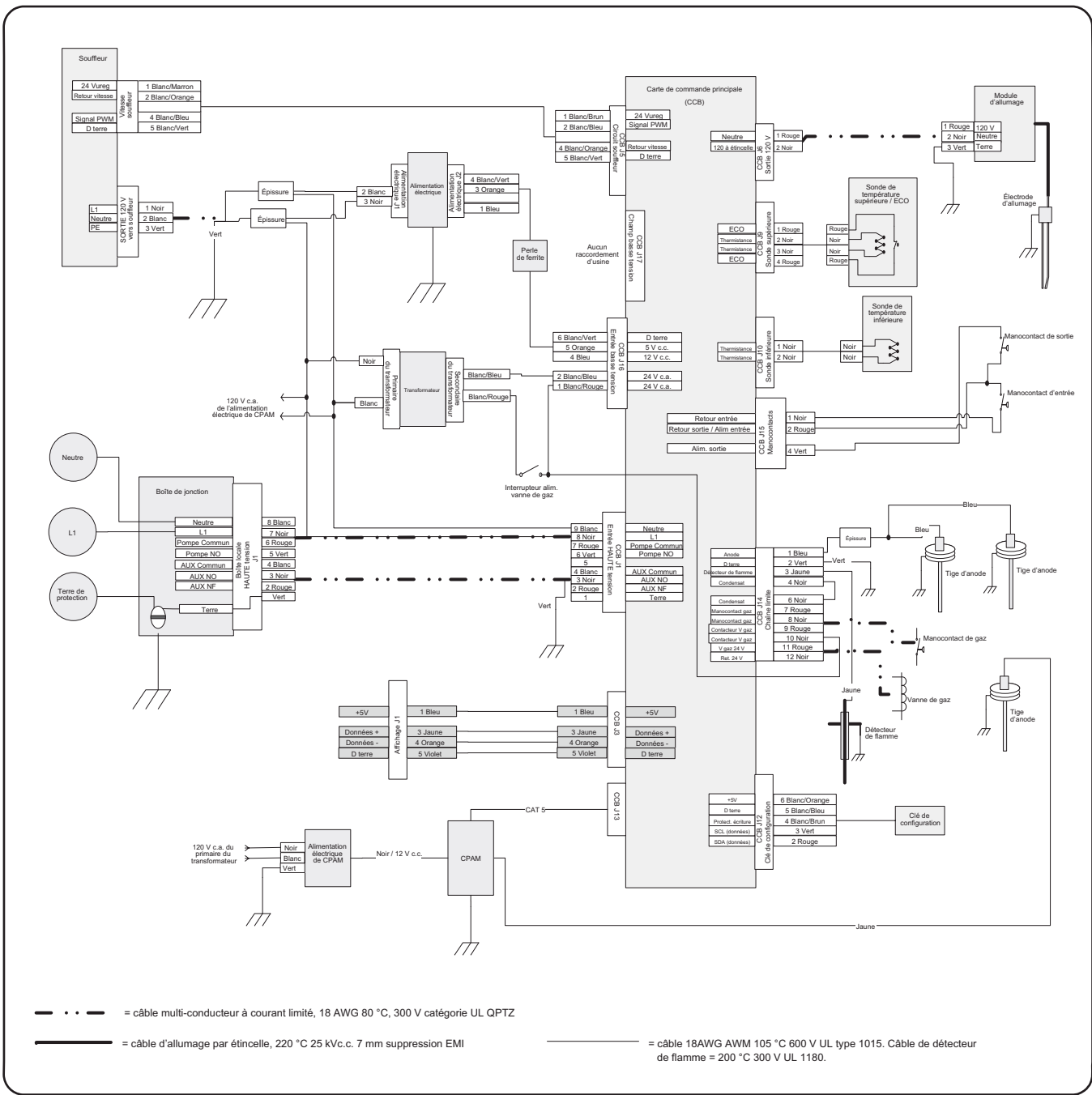

Figure 61