

UNINSULATED BARE STORAGE TANKS

A. O. Smith commercial water storage tanks are designed for use with gas/electric water heaters to provide additional storage capacity for systems with large water draws. A. O. Smith glasslined storage tanks are designed and recommended for systems with operating temperatures up to 180°F.

PERMAGLAS® GLASSLINING

- All internal surfaces exposed to water are glasslined per ASME HLW procedures, using an NSF-approved glasslining compound
- Glass is highly resistant to effects of temperature, corrosion and electrolysis

SIZES FROM 80 TO 2,000 GALLONS

- For horizontal installations, optional tank saddles are recommended (Tanks 500 gallon and above must be specified Horizontal or Vertical)

CATHODIC PROTECTION

- Heavy duty anode rods provide advanced protection against corrosion

WORKING PRESSURES

- Tanks tested at pressures assigned in accordance with working pressures shown in table on reverse side

CUSTOM TANKS

- For our full line of custom tanks, please see the A. O. Smith Custom-Line HD storage tank spec sheet

OPTIONS

- ASME and National Board Certification sheets - furnished upon request
- Tank saddles - two per horizontal tank

FIVE-YEAR LIMITED TANK WARRANTY

- For complete information, consult written warranty or contact A. O. Smith

MODELS T-80 thru T-2000



Legs to be field supplied



**CRN
(OPTIONAL)**

DIMENSION AND SHIPPING WEIGHTS

MODEL NUMBER	TANK CAPACITY USG (L)	OVERALL DIMENSIONS IN (CM)	DIMENSIONS IN (CM)													APPROX. SHIPPING WEIGHT
			A	B	C	D	E	F	G	H	J	K	N	P	LB (KG)	
T-80 STD	80 (303)	20 x 62-1/8 (51 x 158)	20 (51)	61-1/2 (156)	2 (5)	-	7 (18)	2 (5)	3/4 (1)	46-1/4 (117)	16 (41)	3-1/2 (9)	3-1/4 (8)	4 (10)	170 (77)	
T-120 STD	119 (450)	24-1/4 x 65 (62 x 165)	24-1/4 (62)	64-3/8 (164)	2-1/2 (6)	-	7 (18)	2-1/2 (6)	3/4 (1)	34-1/2 (88)	15-1/2 (39)	10-1/2 (27)	3-1/2 (9)	4-1/8 (10)	287 (130)	
T-140 ASME	140 (530)	24 x 76-1/4 (61 x 194)	24 (61)	75 (191)	2-1/2 (6)	8 (20)	12 (30)	2-1/2 (6)	3/4 (1)	27-1/2 (70)	18-1/2 (47)	12 (30)	-	4 (10)	400 (181)	
T-200 ASME	200 (757)	30 x 72 (76 x 183)	30 (76)	70-3/4 (180)	2-1/2 (6)	10 (25)	13 (33)	2-1/2 (6)	3/4 (1)	28-1/2 (72)	19-1/2 (50)	13 (33)	-	4 (10)	460 (209)	
T-250 ASME	250 (946)	30 x 84 (76 x 213)	30 (76)	84 (213)	2-1/2 (6)	10 (25)	13-1/4 (34)	2-1/2 (6)	3/4 (1)	28-1/2 (72)	19-1/2 (50)	13 (33)	-	4 (10)	505 (229)	
T-350 ASME	350 (1,325)	36 x 88 (91 x 224)	36 (91)	86 (218)	2-1/2 (6)	14 (36)	16 (41)	2-1/2 (6)	3/4 (1)	31-1/2 (80)	20-1/4 (51)	16 (41)	-	4 (10)	670 (304)	
T-400 ASME	400 (1,514)	36 x 97 (91 x 246)	36 (91)	96 (244)	2-1/2 (6)	14 (36)	16 (41)	2-1/2 (6)	3/4 (1)	31-1/2 (80)	20-1/4 (51)	16 (41)	-	4 (10)	775 (352)	

Working pressure for T-80 through T-400 models is 160 psi.

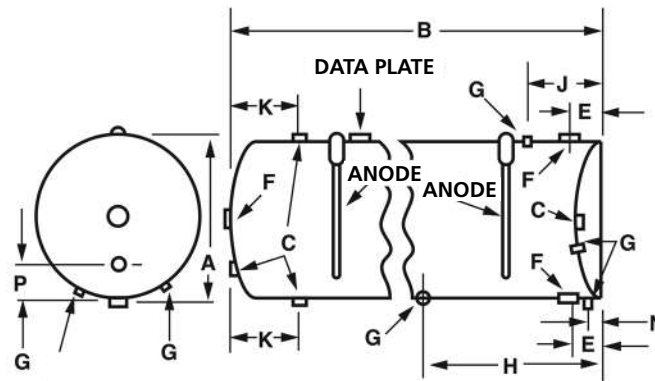

FIGURE 1 - T-80, T-120. NOTE: T-120 SHOWN.

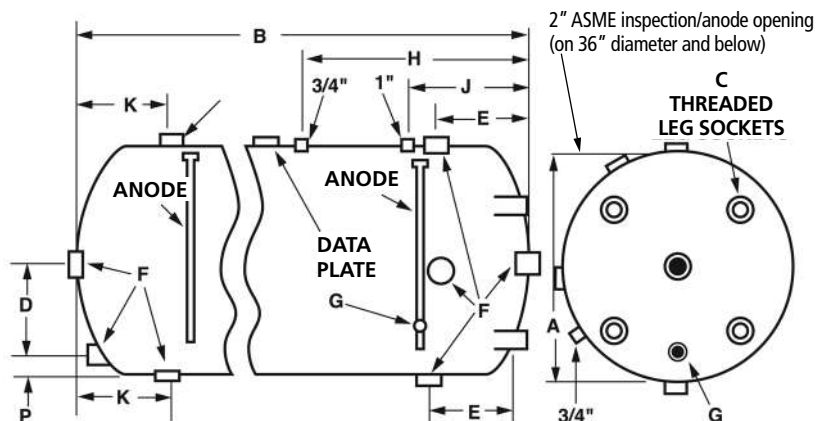

FIGURE 2 - T-140A THRU T-400A

DIMENSION AND SHIPPING WEIGHTS

MODEL NUMBER	TANK CAPACITY	DIMENSIONS IN (CM)				WEIGHT LB (KG) GLASS
	USG (L)	A	B	C	D	
TVN-500A	500 (1,893)	42 (107)	87 (221)	39-3/4 (101)	25-3/4 (65)	763 (346)
TV-500A	500 (1,893)	48 (122)	77 (196)	41-3/4 (106)	27-3/4 (70)	1,062 (482)
TV-600A	600 (2,271)	48 (122)	88 (224)	41-3/4 (106)	27-3/4 (70)	1,193 (541)
TV-700A	700 (2,650)	48 (122)	97 (246)	41-3/4 (106)	27-3/4 (70)	1,301 (590)
TV-750A	750 (2,839)	48 (122)	100 (254)	41-3/4 (106)	27-3/4 (70)	1,337 (606)
TV-1000A	1,000 (3,785)	48 (122)	124 (315)	41-3/4 (106)	27-3/4 (70)	1,623 (736)
TV-1250A	1,250 (4,732)	54 (137)	128 (325)	43-1/4 (110)	29-1/4 (74)	2,100 (953)
TV-1500A	1,500 (5,678)	60 (152)	124 (315)	44-3/4 (114)	30-3/4 (78)	2,709 (1,229)
TV-1750A	1,750 (6,624)	60 (152)	148 (376)	44-3/4 (114)	30-3/4 (78)	3,156 (1,432)
TV-2000A	2,000 (7,571)	72 (183)	121 (307)	47-1/4 (120)	33-1/4 (84)	3,397 (1,541)

Working pressure for 500 through 2000 gallon models is 125 psi.

MODEL NUMBER	TANK CAPACITY	DIMENSIONS IN (CM)						WEIGHT LB (KG) GLASS
	USG (L)	A	B	C	D	E	F	
THN-500A	500 (1,893)	42 (107)	83 (211)	47-1/2 (121)	12 (30)	39-1/2 (100)	27-1/4 (69)	763 (346)
TH-500A	500 (1,893)	48 (122)	73 (185)	40-1/2 (103)	12 (30)	34-1/2 (88)	26-3/4 (68)	1,062 (482)
TH-600A	600 (2,271)	48 (122)	84 (213)	48 (122)	12 (30)	42 (107)	28-1/2 (72)	1,193 (541)
TH-700A	700 (2,650)	48 (122)	93 (236)	52-1/2 (133)	12 (30)	43-1/2 (110)	30-3/4 (78)	1,301 (590)
TH-750A	750 (2,839)	48 (122)	96 (244)	54 (137)	12 (30)	46 (117)	30-3/4 (78)	1,337 (606)
TH-1000A	1,000 (3,785)	48 (122)	120 (305)	66 (168)	12 (30)	35-1/2 (90)	36-1/2 (93)	1,623 (736)

Working pressure for 500 through 1000 gallon models is 125 psi.

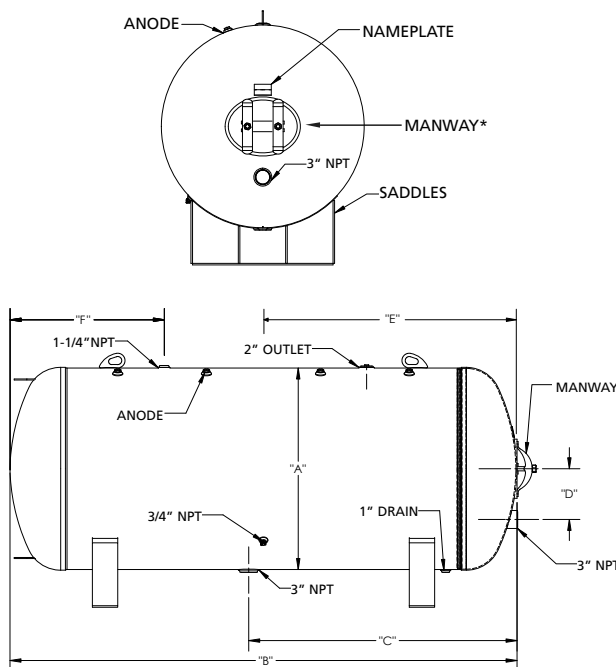

FIGURE 3 THN-500A, TH500A THRU TH-1000A
 * Standard 12" x 16" manway on tanks 500 USG or greater.

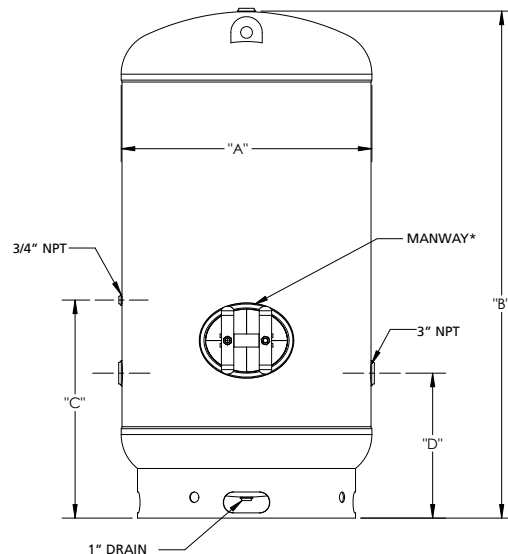

FIGURE 4 - TVN-500A, TV-500A THRU T-2000A

OPTIONAL TANK SADDLES FOR HORIZONTAL TANK INSTALLATIONS

TANK SADDLE DIMENSIONS

Tank Diameter
30 36 42 48 54 60 72

A 21" 25" 29" 34" 48" 52" 62"

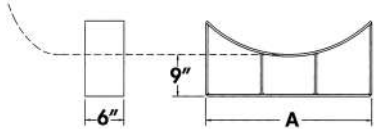

NOTE: Alternate saddle heights are available.
(Consult factory)

TANK SADDLES

A.O. SMITH PART NO.	SADDLE DESCRIPTIONS
100170345	SADDLE, TANK, 24", 9" CLR, P-1
100170349	SADDLE, TANK, 30", 9" CLR, P-1
100170338	SADDLE, TANK, 28", 9" CLR, P-1
100170352	SADDLE, TANK, 36", 9" CLR, P-1
100170355	SADDLE, TANK, 42", 9" CLR, P-1
100170358	SADDLE, TANK, 48", 9" CLR, P-1
100170361	SADDLE, TANK, 54", 9" CLR, P-1
100170365	SADDLE, TANK, 60", 9" CLR, P-1
100170371	SADDLE, TANK, 72", 9" CLR, P-1

SUGGESTED SPECIFICATION

Glasslined storage tank(s) shall be A. O. Smith glasslined storage tank(s) or equal. Tank(s) shall be ____" x ____" and have a nominal capacity of _____ gallons. Tank(s) shall have threaded openings as shown on drawings. Exterior of tank(s) shall be thoroughly cleaned and painted. Interior of tank(s) shall be glasslined with an alkaline borosilicate composition which has been fused to the steel base by firing at a temperature of 1600°F. Cathodic protection shall be provided. The storage tank(s) shall have a working pressure of _____ psi. The storage tank shall have a five-year limited warranty as outlined in the written warranty.

For Technical Information call 888-599-2837. A. O. Smith Enterprises Ltd. reserves the right to make product changes or improvements without prior notice.