

HEAVY-DUTY LARGE VOLUME STORAGE TANKS MODEL HD CUSTOM BUILT

Large volume tanks are designed for storing potable water.

FEATURES

SIZES FROM 120 TO 4,000 GALLONS

All tanks are constructed to the requirements of the ASME Code. These ASME Code tanks are available at 125 and 150 psi working pressure. Consult factory for tanks with special configurations.

LINING AND COATINGS

Each lining and coating has particular capabilities and limitations. Thorough investigation on the service life of steel tanks with protective coatings or linings has led to the recommendation of the following linings:

- Glass Lined — All internal surfaces exposed to water are glass lined per ASME HLW Code procedures.
- Cement Lined — Cement lining consists of a specially formulated cement applied over the interior of the vessel. Cement lined tanks are recommended when storing water at 180°F or higher.
- Epoxy Lined — The application of specially formulated epoxy makes this lining suitable for cold or hot water storage.

Please consult the factory for recommendations on the uses of linings for specific applications. All tanks receive one prime coat of paint on external surface.

CATHODIC PROTECTION

Glass lined and epoxy tanks are furnished with anodes designed for maximum protection.

CUSTOM TANK OPENINGS

All tanks will be supplied with the fittings located as indicated on the drawings unless specified otherwise. Custom tank opening sizes and locations can be provided to your specification.

INSPECTION OPENINGS

- 12" x 16" manhole or 4" x 6" handhole are available as options on diameters 36" and below.
- Two 2" ASME inspection openings are standard on tanks 36" diameter and below.
- 12" x 16" manhole is standard on tanks with 42" diameter and above.

TANK OPTIONS

- Manholes / Handholes
- Additional / Custom Tank Openings
- Lifting Lugs
- Horizontal Tank Saddles
- Factory Jacketing and Insulation
- Tube bundles
- Cement and Epoxy Linings

MODELS
HD-24-120 THROUGH
HD-72-4000

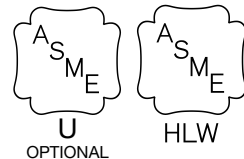



Commercial Storage Tanks

STORAGE TANK SELECTION

MODEL NUMBER	TANK CAPACITY		DIMENSIONS IN (CM)			SHIPPING WEIGHT LB (KG)		
	USG	L	DIAMETER ("A")	VERTICAL HEIGHT ("B")	HORIZONTAL LENGTH ("B")	125 PSI	150 PSI	CEMENT LINED
HD*24-120A	118	447	24 (61)	64 (163)	60 (152)	368 (167)	368 (167)	-
HD*24-140A	141	534	24 (61)	76 (193)	72 (183)	428 (194)	428 (194)	-
HD*24-200A	188	712	24 (61)	100 (254)	96 (244)	556 (252)	556 (252)	-
HD*24-250A	235	890	24 (61)	124 (315)	120 (305)	684 (310)	684 (310)	-
HD*28-175A	175	662	28 (71)	65 (165)	-	353 (160)	353 (160)	-
HD*28-200A	200	757	28 (71)	76 (193)	-	488 (221)	488 (221)	-
HD*30-150A	147	556	30 (76)	52 (132)	48 (122)	400 (181)	400 (181)	695 (315)
HD*30-185A	184	697	30 (76)	64 (163)	60 (152)	468 (212)	468 (212)	812 (368)
HD*30-220A	220	833	30 (76)	76 (193)	72 (183)	548 (249)	548 (249)	958 (435)
HD*30-250A	257	973	30 (76)	87 (221)	83 (211)	628 (285)	628 (285)	1,103 (500)
HD*30-300A	294	1,113	30 (76)	100 (254)	96 (244)	701 (318)	701 (318)	1,242 (563)
HD*30-375A	367	1,389	30 (76)	124 (315)	120 (305)	868 (394)	868 (394)	1,540 (699)
HD*36-275A	265	1,003	36 (91)	64 (163)	60 (152)	577 (262)	577 (262)	995 (451)
HD*36-325A	318	1,204	36 (91)	76 (193)	72 (183)	673 (305)	673 (305)	1,173 (532)
HD*36-400A	370	1,401	36 (91)	87 (221)	83 (211)	770 (349)	770 (349)	1,343 (609)
HD*36-425A	423	1,601	36 (91)	100 (254)	96 (244)	866 (393)	866 (393)	1,513 (686)
HD*36-500A	528	1,999	36 (91)	124 (315)	120 (305)	1,058 (480)	1,058 (480)	1,861 (844)
HD*42-450A	432	1,635	42 (107)	76 (193)	72 (183)	795 (361)	909 (412)	1,385 (628)
HD*42-500A	504	1,908	42 (107)	88 (224)	84 (213)	908 (412)	1,050 (476)	1,587 (720)
HD*42-600A	576	2,180	42 (107)	100 (254)	96 (244)	1,020 (463)	1,190 (540)	1,790 (812)
HD*42-750A	720	2,726	42 (107)	124 (315)	120 (305)	1,245 (565)	1,470 (667)	2,195 (996)
HD*42-900A	864	3,271	42 (107)	148 (376)	144 (366)	1,470 (667)	1,751 (794)	2,601 (1,180)
HD*42-1000A	1,008	3,516	42 (107)	172 (437)	168 (427)	1,695 (769)	2,031 (921)	3,006 (1,363)
HD*48-700A	658	2,491	48 (122)	88 (224)	84 (213)	1,346 (611)	1,346 (611)	2,124 (963)
HD*48-750A	752	2,846	48 (122)	100 (254)	96 (244)	1,507 (684)	1,507 (684)	2,392 (1,085)
HD*48-950A	940	3,558	48 (122)	124 (315)	120 (305)	1,828 (829)	1,828 (829)	2,918 (1,324)
HD*48-1150A	1,128	4,270	48 (122)	148 (376)	144 (366)	2,150 (975)	2,150 (975)	3,444 (1,562)
HD*48-1300A	1,315	4,978	48 (122)	172 (437)	168 (427)	2,471 (1,121)	2,471 (1,121)	3,970 (1,801)
HD*48-1500A	1,503	5,689	48 (122)	196 (498)	192 (488)	2,793 (1,267)	2,793 (1,267)	4,505 (2,043)
HD*54-1000A	951	3,560	54 (137)	100 (254)	96 (244)	1,721 (781)	1,972 (894)	2,729 (1,238)
HD*54-1200A	1,189	4,501	54 (137)	124 (315)	120 (305)	2,083 (945)	2,423 (1,099)	3,320 (1,506)
HD*54-1450A	1,427	5,402	54 (137)	148 (376)	144 (366)	2,451 (1,112)	2,881 (1,307)	3,919 (1,778)
HD*54-1700A	1,665	6,303	54 (137)	172 (437)	168 (427)	2,807 (1,273)	3,326 (1,509)	4,511 (2,046)
HD*54-1900A	1,903	7,204	54 (137)	196 (498)	192 (488)	3,168 (1,437)	3,777 (1,713)	5,102 (2,314)
HD*54-2150A	2,141	8,105	54 (137)	220 (559)	216 (549)	3,530 (1,601)	4,228 (1,918)	5,701 (2,586)
HD*60-1500A	1,469	5,561	60 (152)	124 (315)	120 (305)	2,784 (1,263)	3,221 (1,461)	4,177 (1,895)
HD*60-1750A	1,763	6,673	60 (152)	148 (376)	144 (366)	3,267 (1,482)	3,823 (1,734)	4,913 (2,228)
HD*60-2000A	2,056	7,783	60 (152)	172 (437)	168 (427)	3,749 (1,701)	4,425 (2,007)	5,658 (2,566)
HD*60-2400A	2,350	8,896	60 (152)	196 (498)	192 (488)	4,231 (1,919)	5,026 (2,280)	6,394 (2,900)
HD*60-2650A	2,644	10,009	60 (152)	220 (559)	216 (549)	4,713 (2,138)	5,628 (2,553)	7,130 (3,234)
HD*72-2100A	2,115	8,006	72 (183)	124 (315)	120 (305)	3,416 (1,549)	3,904 (1,771)	5,104 (2,315)
HD*72-2500A	2,538	9,607	72 (183)	148 (376)	144 (366)	3,995 (1,812)	-	5,995 (2,719)
HD*72-3000A	2,961	11,209	72 (183)	172 (437)	168 (427)	4,575 (2,075)	-	6,885 (3,123)
HD*72-3400A	3,384	12,810	72 (183)	196 (498)	192 (488)	5,154 (2,338)	-	7,767 (3,523)
HD*72-4000A	3,807	14,411	72 (183)	220 (559)	216 (549)	5,733 (2,600)	-	8,658 (3,927)

* For H e.g. (HDH48-1500A) or V e.g. (HDV48-1500A)

Specify Horizontal or Vertical installation H or V (after the HD)

For Jacketed models, the J will follow the orientation: HDVJ48-1500A.

For linings other than glass, use the suffix after the number and the A - HDHJ42-1000AE for Epoxy lined or HDHJ42-1000AC for Cement lined. U = Unlined.

For 150 psi ASME working pressure, insert M at the end - HDV42 - 1000AM.

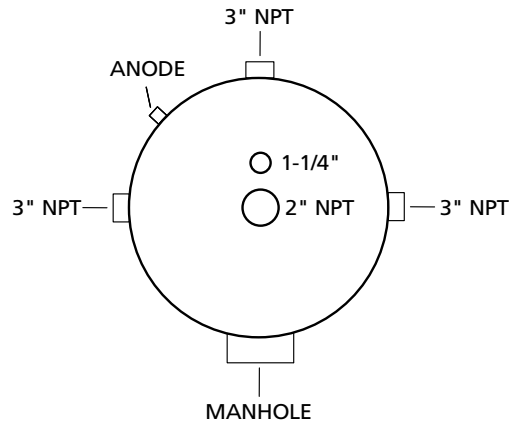
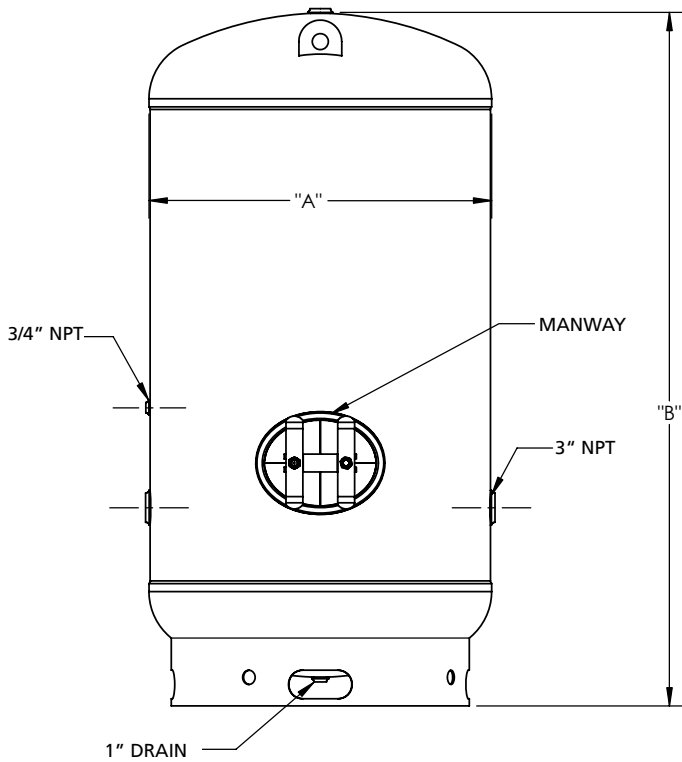

NOTE:
 SPECIFY FOR HORIZONTAL OR VERTICAL INSTALLATION.
 2 each 2" ASME inspection openings are standard on tanks 36" diameter and below.
 12"x16" ASME inspection openings are standard on tanks with 42" diameter and above.

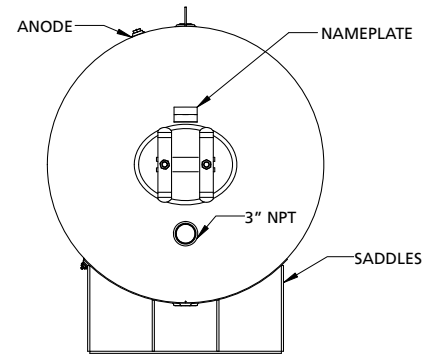
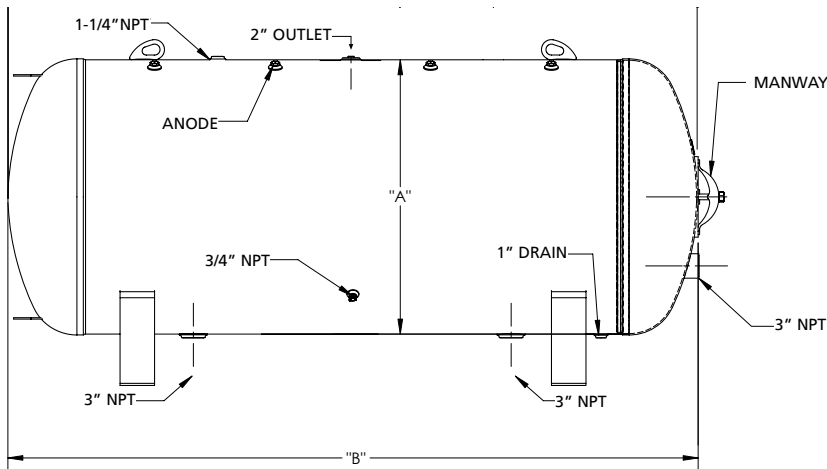

30" - 72" DIAMETER HORIZONTAL TANKS

TANK SADDLE DIMENSIONS

Tank Diameter
30 36 42 48 54 60 72

A 21" 25" 29" 34" 48" 52" 62"

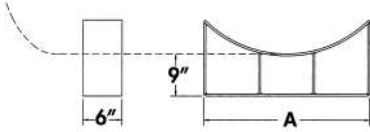

NOTE: Alternate saddle heights are available.
 (Consult factory)

TANK SADDLES

A.O. SMITH PART NO.	SADDLE DESCRIPTIONS
100170345	SADDLE, TANK, 24", 9" CLR, P-1
100170349	SADDLE, TANK, 30", 9" CLR, P-1
100170338	SADDLE, TANK, 28", 9" CLR, P-1
100170352	SADDLE, TANK, 36", 9" CLR, P-1
100170355	SADDLE, TANK, 42", 9" CLR, P-1
100170358	SADDLE, TANK, 48", 9" CLR, P-1
100170361	SADDLE, TANK, 54", 9" CLR, P-1
100170365	SADDLE, TANK, 60", 9" CLR, P-1
100170371	SADDLE, TANK, 72", 9" CLR, P-1

FACTORY INSULATION OPTIONS

Factory Jacketed and Insulation

- **INSULATION** — Entire tank is surrounded with insulation.
- **CABINET** — Heavy gauge painted steel.
- Adds 4" to the round jacketed and 6" to the square jacketed diameter of the tank, and 2" to the height.
- Units with length/height greater than 125" cannot be jacketed and insulated at the factory.

SUGGESTED SPECIFICATION

SAMPLE SPECIFICATION FOR CUSTOM-LINE STORAGE TANKS

When jacketed or insulated these models meet or exceed the thermal efficiency and standby loss requirements of ASHRAE 90.1b (current standard).

ASME storage tank to be A. O. Smith Custom-Line model _____. Capacity to be _____gallons with a diameter of _____ inches. Tank(s) shall be constructed and stamped according to ASME specifications for _____psi working pressure. Manhole (12" x 16"), handhole (4" x 6") or inspection openings (2-2') shall be installed in accordance with ASME code requirements and manufacturer(s) standard practice. Tank to be constructed of (carbon steel) _____. Lining shall be (glass, epoxy, cement) _____. Tank(s) lined with (glass, cement, epoxy) _____lining shall be equipped with the number and size of anode rod(s) sufficient to provide adequate protection for the tank lining. Tank shall be (vertical, horizontal) _____ design and provided with (four) _____ ring base, _____ saddles.

For Technical Information call 888-599-2837. A. O. Smith Enterprises Ltd. reserves the right to make product changes or improvements without prior notice.