

## GOLD Xi SERIES COMMERCIAL ELECTRIC WATER HEATER

Designed for use as a recovery heater having its own storage tank or booster for supplying sanitizing rinse water for dish washing.

### FEATURES

- Meets the thermal efficiency and or standby loss requirements of NRCan and current edition of ASHRAE/IES 90.1.

### ADVANCED ELECTRONIC CONTROL

- Easy to understand text and animated icons display detailed operational and diagnostic information. Fault or Alert messages appear if an operational issue occurs.
- Immersion temperature control adjustable through a range of 90°F to 190°F.

### BMS

- BACnet and Modbus compatible using optional BMS Gateway module. Call 888-928-3702 for information.

### ECONOMY MODE OPERATION

- Control system automatically lowers the Operating Set Point by a programmed value during user-defined time periods. Helps reduce operating costs during unoccupied or off-peak demand periods.

### LINEAR SEQUENCING

- Banks of heating elements (3 elements per bank) are energized according to adjustable (1 to 20°F) differential set points for each bank. First bank on is the last bank off. Helps reduce current surge and provides accurate water temperature control.

### INCOLOY ELEMENTS

- All models come standard with heavy duty incoloy elements.

### GLASS-LINED TANK

- Three sizes; 50, 80 and 119 gallon capacity. Tank interior is coated with glass specially developed by A. O. Smith for water heater use. Foam insulation reduces costly heat loss. Tanks rated at 150 psi (1034 kPa) working pressure.

### POWER CIRCUIT FUSING

- Protects elements and contactors from short circuits, overloading or line surges.

### STANDARD VOLTAGES

- 208, 240 and 480V single-phase and three phase delta. Convertible from three-phase to single-phase (in field) and vice versa (except 208/54 kW). 277V single-phase also available.

### TERMINAL BLOCK

- Factory installed. Allows for easy service connection to block.

### MAGNETIC CONTACTORS

- Heavy duty; UL rated 100,000 cycles.

### THREE YEAR LIMITED TANK WARRANTY

- For complete warranty information, consult written warranty or go to hotwater.com.

### OTHER STANDARD FEATURES

- Immersion style thermostats
- Simplified circuitry, colour coded for ease of service
- Hinged control compartment door for quick, easy access
- Two anode rods for maximum corrosion protection
- Cabinet has bonderized undercoat with baked enamel finish
- Top outlet, side inlet and relief valve openings
- Nipple and brass drain valve
- CSA certified and ASME rated T&P relief valve.



## MODELS DVE-52, 80, 120

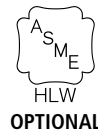

## OPTIONS:

- ASME 160 psi (1103 kPa) tank construction.
- UL Listed conversion kits to adjust voltage and kW requirement in the field before and after installation.
- Manifold kits for multiple tank installations. Two heaters -part # 100109231, three heaters- part # 100109232 and four heaters- part # 100109233.
- International voltages – 220, 380, 400, 415, 575, and 600 volts, three phase available with Y connected elements.

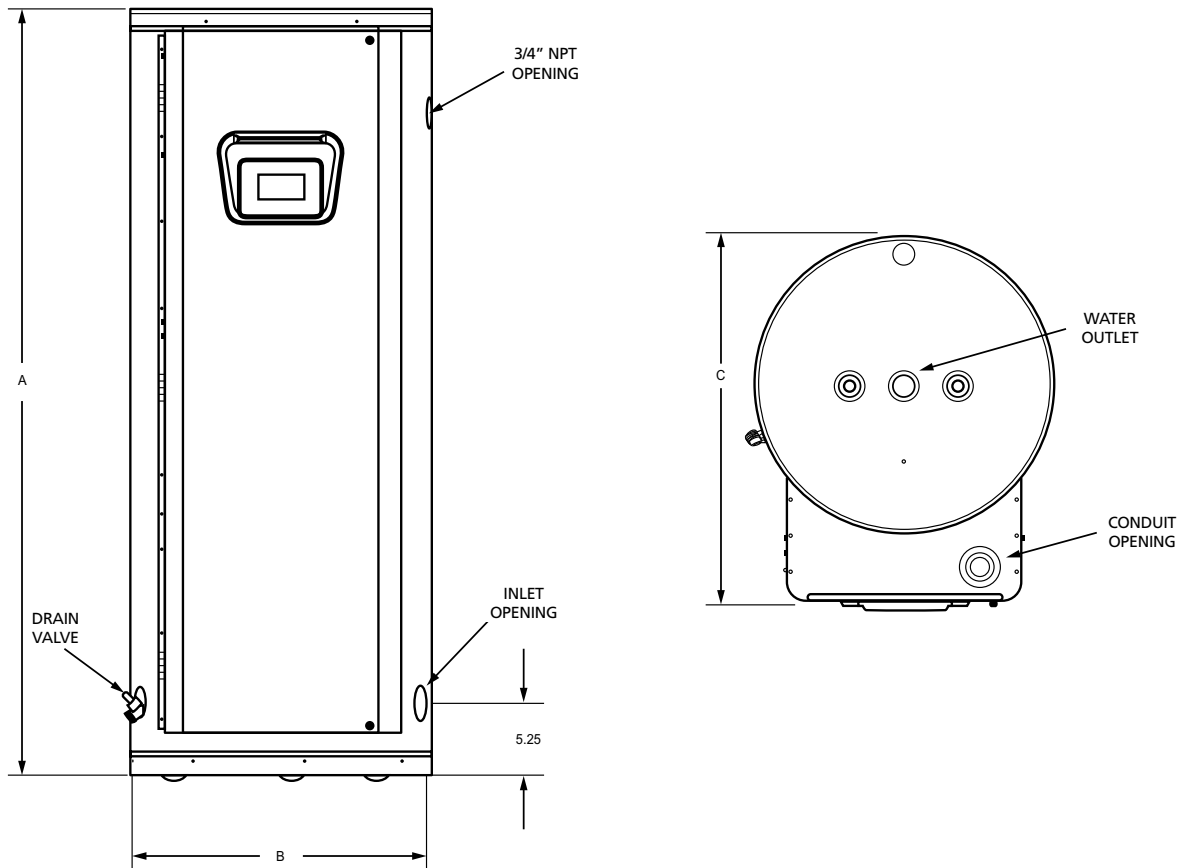

## ROUGH-IN DIMENSIONS

MODEL NUMBER	TANK CAPACITY		DIMENSIONS						INLET/OUTLET (NPT)	APPROX. SHIPPING WEIGHT	
			A		B		C			LB	KG
	USG	LITRE	INCHES	CM	INCHES	CM	INCHES	CM	INCHES		
DVE-52	50	179	55-3/4	142	21-3/4	55	27	69	1-1/4	265	120
DVE-80	80	286	60-1/4	153	25-1/2	65	31	79	1-1/4	280	127
DVE-120	119	426	62-1/4	158	29-1/2	75	35	89	1-1/4	390	177

For ASME construction add "A" to the model number (example: DVE - 52A 24).



# Commercial Electric Water Heaters

## RECOVERY CAPACITIES

STANDARD KW INPUT	BTU/h	30°F	40°F	50°F	60°F	70°F	80°F	90°F	100°F	110°F	120°F	130°F	140°F
		17°C	22°C	28°C	33°C	39°C	45°C	50°C	56°C	61°C	67°C	72°C	78°C
6	20,478	82	62	49	41	35	31	27	25	22	21	19	18
		310	233	166	155	133	116	103	93	85	78	72	66
9	30,717	123	92	74	62	53	46	41	37	34	31	28	26
		465	349	279	223	199	174	155	140	127	116	107	100
12	40,956	164	123	98	82	70	61	55	49	45	41	38	35
		620	465	372	310	266	233	207	186	169	155	143	133
13.5	46,075	184	138	111	92	79	69	62	55	50	46	43	40
		698	523	419	349	299	262	233	209	190	174	161	150
15	51,195	205	154	123	102	88	77	68	61	56	51	47	44
		775	582	465	388	332	291	258	233	211	194	149	166
18	61,434	246	184	148	123	105	92	82	74	67	62	57	53
		930	698	558	465	399	349	310	279	254	233	215	199
24	81,912	328	246	197	164	140	123	109	98	90	82	76	70
		1241	930	744	620	532	465	414	372	338	310	286	266
27	92,151	369	276	221	185	158	138	123	111	101	92	85	79
		1396	1047	938	609	509	523	465	410	391	340	322	299
30	102,390	410	307	246	205	176	154	137	123	112	102	95	88
		1551	1163	930	775	665	582	517	465	423	388	358	332
36	122,868	492	369	295	246	211	184	164	148	134	123	113	105
		1861	1396	1117	930	798	698	620	556	508	465	429	399
40.5	138,226	554	418	332	277	237	208	185	166	151	138	128	119
		2094	1570	1256	1047	897	785	698	628	634	582	537	498
45	153,585	615	461	369	307	263	230	205	184	168	154	142	132
		2326	1745	1398	1163	997	872	755	698	634	582	537	498
54	184,302	738	554	443	359	316	277	246	221	20	185	170	158
		2791	2094	1675	1396	1196	1047	930	837	761	696	644	598

Figured at 1 kW (3413 BTU) = 4.1 Gallons at 100°F temperature rise.



# Commercial Electric Water Heaters

KW INPUT	MODEL NUMBERS TANK CAPACITY IN GALLONS			NUMBER OF ELEMENTS	ELEMENT WATTAGE	FULL LOAD CURRENT IN AMPERES							
						SINGLE PHASE				THREE PHASE			
	50	80	119			208V	240V	277V	480V	208V	240V	480V	600V
6	N/A	DVE-80-6	DVE-120-6	3	2,000	28.8	25	21.7	12.5	16.7	14.4	7.2	6.0
9	N/A	DVE-80-9	DVE-120-9	3	3,000	43.3	37.5	32.5	18.8	25	21.7	10.8	9.0
12	N/A	DVE-80-12	DVE-120-12	3	4,000	57.7	50	43.3	25	33.3	28.9	14.4	12.0
13.5	DVE-52-13.5	DVE-80-13.5	DVE-120-13.5	3	4,500	64.9	56.3	48.7	28.1	37.5	32.5	16.2	13.5
15	DVE-52-15	DVE-80-15	DVE-120-15	3	5,000	72.1	62.5	54.2	31.3	41.6	36.1	18	15.0
18	DVE-52-18	DVE-80-18	DVE-120-18	3*	6,000	86.5	75	65	37.5	50	43.3	21.7	18.0
24	DVE-52-24	DVE-80-24	DVE-120-24	6	4,000	115.4	100	86.6	50	66.6	57.7	28.9	24.0
27	DVE-52-27	DVE-80-27	DVE-120-27	6	4,500	129.8	112.5	97.5	56.3	74.9	65	32.5	27.0
30	DVE-52-30	DVE-80-30	DVE-120-30	6	5,000	144.2	125	108.3	62.5	83.3	72.2	36.1	30.0
36	DVE-52-36	DVE-80-36	DVE-120-36	6*	6,000	173.1	150	130	75	99.9	86.6	43.3	36.0
40.5	DVE-52-40.5	DVE-80-40.5	DVE-120-40.5	9	4,500	194.7	168.8	146.2	84.4	112.4	97.4	48.7	40.5
45	DVE-52-45	DVE-80-45	DVE-120-45	9	5,000	216.3	187.5	162.5	93.8	124.9	108.3	54.1	45.0
54	DVE-52-54	DVE-80-54	DVE-120-54	9	6,000	N/A	225	194.9	112.5	149.9	129.9	65	54.0

\*208 volt models may contain three (3) additional elements.  
For ASME construction add "A" to the model number (example: DVE-52A 24).

## SUGGESTED SPECIFICATION

The heater(s) shall be Gold Xi Commercial Electric Model Number \_\_\_\_\_ as manufactured by A. O. Smith or equivalent. Heater(s) shall be rated at \_\_\_\_\_ kW \_\_\_\_\_ V \_\_\_\_\_ phase, 60 cycle AC as listed by Underwriters' Laboratories. All models meet National Sanitation Foundation NSF-5 requirements. Water heater shall have LCD display with built-in diagnostic and troubleshooting information. Tank(s) shall be \_\_\_\_\_ (50, 80 or 119) gallon capacity with \_\_\_\_\_ (150 [Std] or 160 [ASME]) psi working pressure and equipped with dual extruded high density anodes. All internal surfaces of the heater(s) exposed to water shall be glass-lined with an alkaline borosilicate composition that has been fused to steel by firing at a temperature range of 1400°F to 1600°F. Internal power circuit fusing shall be provided. Element operation shall be linear sequencing through individual magnetic contactors. Control circuit shall be factory fused and include an immersion thermistor temperature probe with built in ECO control. Control cabinet and jacket shall be of baked enamel finish and shall provide full size control and element compartment for complete service and maintenance performance through front hinged compartment door, and enclose tank with foam insulation. 1 1/4" inlet and outlet connection shall be provided. The heater tank shall have a three year limited warranty and controls and accessories shall have a one year limited warranty as outlined in the written warranty. Fully illustrated instruction manual to be included. For multiple installation, factory built manifold kits for \_\_\_\_\_ (2, 3 or 4) heater installation shall be provided. Meets or exceeds the thermal efficiency and standby loss requirements of NRCAN and current edition of ASHRAE/IES 90.1.

For Technical Information call 888-599-2837. A. O. Smith Enterprises Ltd. reserves the right to make product changes or improvements without prior notice.