

GOLD SERIES COMMERCIAL ELECTRIC WATER HEATER

Designed for use as a recovery heater having its own storage tank.

Note: Not recommended for sanitizing water applications.

FEATURES

- Meets the standby loss requirements of NRCAN and current edition of AHRAE/IES 90.1.

INCOLOY IMMERSION HEATERS

- Heavy-duty medium watt density elements (three/immersion heater) have incoloy sheathing: provide excellent protection against oxidation and scaling.

GLASSLINED TANK

- Three sizes: 50, 80 and 119 gallon capacity. Tank interior is coated with glass specially developed by A. O. Smith for water heater use. Tanks rated at 150 psi (1034 kPa) working pressure.

FUSING

- Protects all elements, thermostats, and internal wiring circuits against excess current flow.

STANDARD VOLTAGES

- 208, 240 and 480V single-phase and three-phase delta. Convertible from three-phase to single-phase (in field) and vice versa. 277V single-phase also available.

TERMINAL BLOCK

- Factory installed. Just bring the electrical service to the heater and connect to block.

CONTROLS

- One temperature control (adjustable through a range of 120° to 181°F) and manual reset high temperature cut-off per element. Thermostat step control may be achieved by varying settings on individual temperature controls. Located behind hinged control compartment door for quick, easy access.

OTHER STANDARD FEATURES

- Surface mounted thermostats
- Simplified circuitry, colour coded for ease of service
- Two anode rods for maximum corrosion protection
- Cabinet has bonderized undercoat with baked enamel finish
- Bottom inlet and top outlet openings
- Brass drain valve
- CSA Certified and ASME rated T&P relief valve
- Single panel control box
- Foam insulation reduces costly heat loss.

3-YEAR LIMITED TANK / 1-YEAR LIMITED PARTS WARRANTY

- For complete warranty information, consult written warranty or go to hotwater.com.



MODELS
DRE-52, 80, 120



OPTIONAL

OPTIONS

- UL and cUL listed conversion kits to adjust voltage and kW requirements in the field before and after installation
- ASME 160 psi (1103 kPa) tank construction
- International voltages – 220, 380, 400, 415, 575, and 600 volts, three phase available with Y connected elements
- MANIFOLD KITS – for multiple tank installations. Two heaters -part # 100109231, three heaters- part # 100109232 and four heaters- part # 100109233

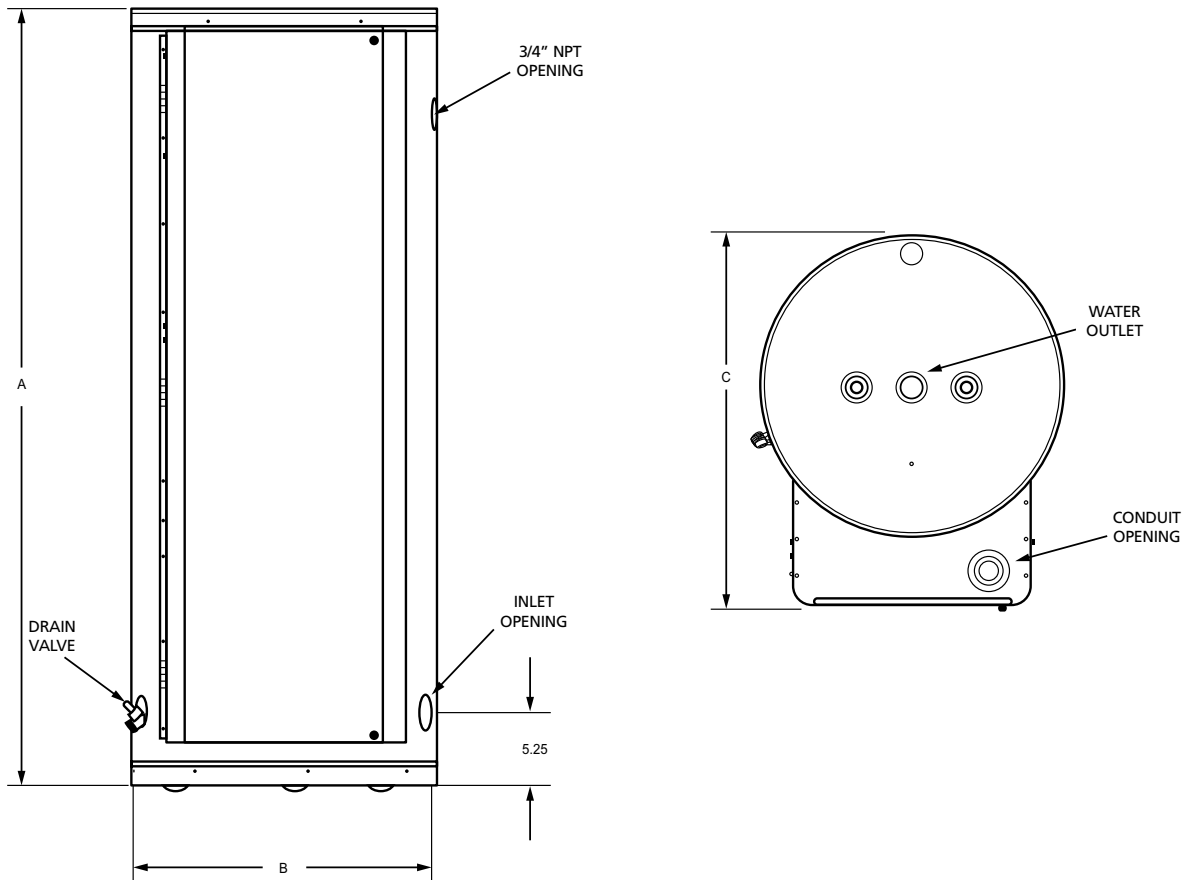

DIMENSIONS

MODEL NUMBER	TANK CAPACITY		DIMENSIONS						INLET/OUTLET (NPT)	APPROX. SHIPPING WEIGHT	
			A		B		C				
	USG	LITRE	INCHES	CM	INCHES	CM	INCHES	CM	INCHES	LB	KG
DRE-52	50	179	55-3/4	142	21-3/4	55	27	69	1-1/4	265	120
DRE-80	80	286	60-1/4	153	25-1/2	65	31	79	1-1/4	280	127
DRE-120	119	426	62-1/4	158	29-1/2	75	35	89	1-1/4	390	177

For ASME Construction add "A" to the model number (example: DRE 52A 24).



Commercial Electric Water Heaters

RECOVERY CAPACITIES

STANDARD KW INPUT	BTU/h	30°F	40°F	50°F	60°F	70°F	80°F	90°F	100°F	110°F	120°F	130°F	140°F
		17°C	22°C	28°C	33°C	39°C	45°C	50°C	56°C	61°C	67°C	72°C	78°C
6	20,478	82	62	49	41	35	31	27	25	22	21	19	18
		310	233	166	155	133	116	103	93	85	78	72	66
9	30,717	123	92	74	62	53	46	41	37	34	31	28	26
		465	349	279	233	199	174	155	140	127	116	107	100
12	40,956	164	123	98	82	70	61	55	49	45	41	38	35
		620	465	372	310	266	233	207	186	169	155	143	133
13.5	46,075	184	138	111	92	79	69	62	55	50	46	43	40
		698	523	419	349	299	262	233	209	190	174	161	150
15	51,195	205	154	123	102	88	77	68	61	56	51	47	44
		775	582	465	388	332	291	258	233	211	194	149	166
18	61,434	246	184	148	123	105	92	82	74	67	62	57	53
		930	698	558	465	399	349	310	279	254	233	215	199
24	81,912	328	246	197	164	140	123	109	98	90	82	76	70
		1241	930	744	620	532	465	414	372	338	310	286	266
27	92,151	369	276	221	185	158	138	123	111	101	92	85	79
		1396	1047	938	609	509	523	465	410	391	340	322	299
30	102,390	410	307	246	205	176	154	137	123	112	102	95	88
		1551	1163	930	775	665	582	517	465	423	388	358	332
36	122,868	492	369	295	246	211	184	164	148	134	123	113	105
		1861	1396	1117	930	798	698	620	556	508	465	429	399
40.5	138,226	554	418	332	277	237	208	185	166	151	138	128	119
		2094	1570	1256	1047	897	785	698	628	634	582	537	498
45	153,585	615	461	369	307	263	230	205	184	168	154	142	132
		2326	1745	1398	1163	997	872	755	698	634	582	537	498
54	184,302	738	554	443	359	316	277	246	221	201	185	170	158
		2791	2094	1675	1396	1196	1047	930	837	761	696	644	598

Figured at 1 kW (3413 BTU) = 4.1 Gallons at 100°F temperature rise.



Commercial Electric Water Heaters

KW INPUT	MODEL NUMBERS TANK CAPACITY IN GALLONS			NUMBER OF ELEMENTS	ELEMENT WATTAGE	FULL LOAD CURRENT IN AMPERES							
	50	80	119			SINGLE PHASE				THREE PHASE			
						208V	240V	277V	480V	208V	240V	480V	600V
6	DRE-52-6	DRE-80-6	DRE-120-6	3	2,000	28.8	25.0	21.7	12.5	16.7	14.4	7.2	6.0
9	DRE-52-9	DRE-80-9	DRE-120-9	3	3,000	43.3	37.5	32.5	18.8	25.0	21.7	10.8	9.0
12	DRE-52-12	DRE-80-12	DRE-120-12	3	4,000	57.7	50.0	43.3	25.0	33.3	28.9	14.4	12.0
13.5	DRE-52-13.5	DRE-80-13.5	DRE-120-13.5	3	4,500	64.9	56.3	48.7	28.1	37.5	32.5	16.2	13.5
15	DRE-52-15	DRE-80-15	DRE-120-15	3	5,000	72.1	62.5	54.2	31.3	41.6	36.1	18.0	15.0
18	DRE-52-18	DRE-80-18	DRE-120-18	3*	6,000	86.5	75.0	65.0	37.5	50.0	43.3	21.7	18.0
24	DRE-52-24	DRE-80-24	DRE-120-24	6	4,000	115.4	100.0	86.6	50.0	66.6	57.7	28.9	24.0
27	DRE-52-27	DRE-80-27	DRE-120-27	6	4,500	129.8	112.5	97.5	56.3	74.9	65.0	32.5	27.0
30	DRE-52-30	DRE-80-30	DRE-120-30	6	5,000	144.2	125.0	108.3	62.5	83.3	72.2	36.1	30.0
36	DRE-52-36	DRE-80-36	DRE-120-36	6*	6,000	173.1	150.0	130.0	75.0	99.9	86.6	43.3	36.0
40.5	N/A	DRE-80-40.5	DRE-120-40.5	9	4,500	194.7	168.8	146.2	84.4	112.4	97.4	48.7	40.5
45	N/A	DRE-80-45	DRE-120-45	9	5,000	216.3	187.5	162.5	93.8	124.9	108.3	54.1	45.0
54	N/A	DRE-80-54	DRE-120-54	9	6,000	N/A	225.0	194.9	112.5	149.9	129.9	65.0	54.0

*208 volt models may contain three (3) additional elements.
For ASME construction add "A" to the model number (example: DRE-52A-24).

SUGGESTED SPECIFICATION

The heater(s) shall be Gold Series Commercial Electric Model Number _____ as manufactured by A. O. Smith. Heater(s) shall be rated at _____ kW, _____ volts, _____ phase, 60 cycle AC, and listed by Underwriters' Laboratories and approved to the NSF Standard 5 by UL. Tank(s) shall be _____ (50, 80 or 119) gallon capacity. Tanks shall have _____ (150 [Std] or 160 [ASME]) psi working pressure and be equipped with extruded high density anode. All internal surfaces of the heater(s) exposed to water shall be glasslined with an alkaline borosilicate composition that has been fused-to-steel by firing at a temperature range of 1400°F to 1600°F. Electric heating elements shall be low watt density. Each element shall be controlled by an individually mounted thermostat and high temperature cut-off switch. All internal circuits shall be fused. The outer jacket shall be of baked enamel finish and shall be provided with full size control compartment for performance of service and maintenance through hinged front panel and shall enclose the tank with foam insulation. Electrical junction box with heavy duty terminal block shall be provided. The drain valve shall be located in the front for ease of servicing. Heater tank shall have a three year limited warranty as outlined in the written warranty. Manufacturer shall supply ASME rated temperature and pressure relief valve. Fully illustrated instruction manual to be included. Meets standby loss requirements of NRCAN and current edition of ASHRAE/IES 90.1.

For Technical Information call 888-599-2837. A. O. Smith Enterprises Ltd. reserves the right to make product changes or improvements without prior notice.